





5

**The Processor:
Datapath
and Control**

*In a major matter,
no details are small.*

French Proverb

| | | |
|---|---|-----|
| 5.1 | Introduction | 284 |
| 5.2 | Logic Design Conventions | 289 |
| 5.3 | Building a Datapath | 292 |
| 5.4 | A Simple Implementation Scheme | 300 |
| 5.5 | A Multicycle Implementation | 318 |
| 5.6 | Exceptions | 340 |
|  | 5.7 Microprogramming: Simplifying Control Design | 346 |
|  | 5.8 An Introduction to Digital Design Using a Hardware Design Language | 346 |
| 5.9 | Real Stuff: The Organization of Recent Pentium Implementations | 347 |
| 5.10 | Fallacies and Pitfalls | 350 |
| 5.11 | Concluding Remarks | 352 |
|  | 5.12 Historical Perspective and Further Reading | 353 |
| 5.13 | Exercises | 354 |

The Five Classic Components of a Computer

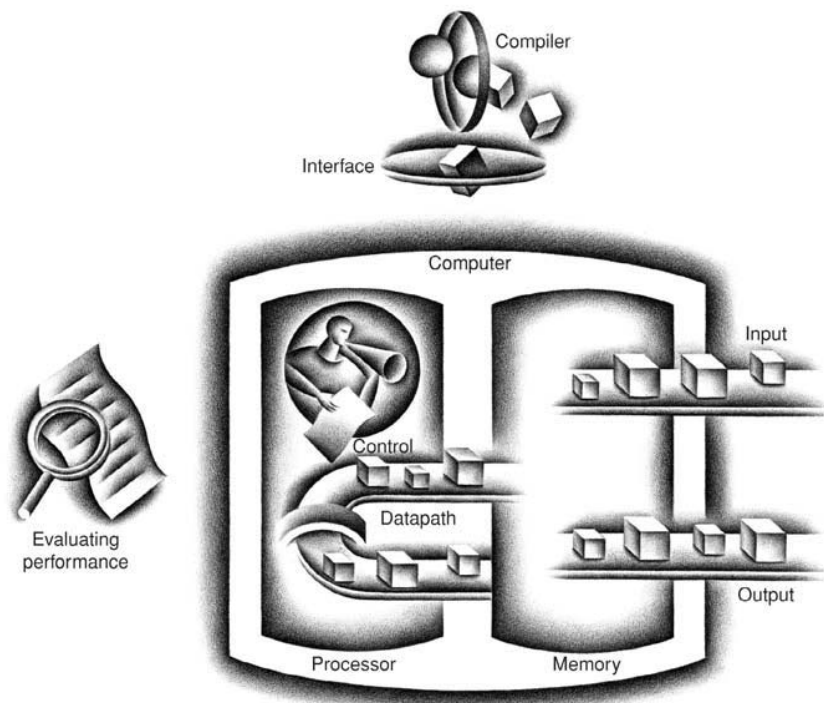

5.1 Introduction

In Chapter 4, we saw that the performance of a machine was determined by three key factors: instruction count, clock cycle time, and clock cycles per instruction (CPI). The compiler and the instruction set architecture, which we examined in Chapters 2 and 3, determine the instruction count required for a given program. However, both the clock cycle time and the number of clock cycles per instruction are determined by the implementation of the processor. In this chapter, we construct the datapath and control unit for two different implementations of the MIPS instruction set.

This chapter contains an explanation of the principles and techniques used in implementing a processor, starting with a highly abstract and simplified overview in this section, followed by sections that build up a datapath and construct a simple version of a processor sufficient to implement instructions sets like MIPS, and finally, developing the concepts necessary to implement more complex instructions sets, like the IA-32.

For the reader interested in understanding the high-level interpretation of instructions and its impact on program performance, this initial section provides enough background to understand these concepts as well as the basic concepts of pipelining, which are explained in Section 6.1 of the next chapter.

For those readers desiring an understanding of how hardware implements instructions, Sections 5.3 and 5.4 are all the additional material that is needed. Furthermore, these two sections are sufficient to understand all the material in Chapter 6 on pipelining. Only those readers with an interest in hardware design should go further.

The remaining sections of this chapter cover how modern hardware—including more complex processors such as the Intel Pentium series—is usually implemented. The basic principles of finite state control are explained, and different methods of implementation, including microprogramming, are examined. For the reader interested in understanding the processor and its performance in more depth, Sections 5.4 and 5.5 will be useful. For readers with an interest in modern hardware design, [Section 5.7](#) covers microprogramming, a technique used to implement more complex control such as that present in IA-32 processors, and [Section 5.8](#) describes how hardware design languages and CAD tools are used to implement hardware.

A Basic MIPS Implementation

We will be examining an implementation that includes a subset of the core MIPS instruction set:

- The memory-reference instructions load word (`lw`) and store word (`sw`)
- The arithmetic-logical instructions `add`, `sub`, `and`, `or`, and `sllt`
- The instructions branch equal (`beq`) and jump (`j`), which we add last

This subset does not include all the integer instructions (for example, shift, multiply, and divide are missing), nor does it include any floating-point instructions. However, the key principles used in creating a datapath and designing the control will be illustrated. The implementation of the remaining instructions is similar.

In examining the implementation, we will have the opportunity to see how the instruction set architecture determines many aspects of the implementation, and how the choice of various implementation strategies affects the clock rate and CPI for the machine. Many of the key design principles introduced in Chapter 4 can be illustrated by looking at the implementation, such as the guidelines *Make the common case fast* and *Simplicity favors regularity*. In addition, most concepts used to implement the MIPS subset in this chapter and the next are the same basic ideas that are used to construct a broad spectrum of computers, from high-performance servers to general-purpose microprocessors to embedded processors, which are used increasingly in products ranging from VCRs to automobiles.

An Overview of the Implementation

In Chapters 2 and 3, we looked at the core MIPS instructions, including the integer arithmetic-logical instructions, the memory-reference instructions, and the branch instructions. Much of what needs to be done to implement these instructions is the same, independent of the exact class of instruction. For every instruction, the first two steps are identical:

1. Send the program counter (PC) to the memory that contains the code and fetch the instruction from that memory.
2. Read one or two registers, using fields of the instruction to select the registers to read. For the load word instruction, we need to read only one register, but most other instructions require that we read two registers.

After these two steps, the actions required to complete the instruction depend on the instruction class. Fortunately, for each of the three instruction classes (memory-reference, arithmetic-logical, and branches), the actions are largely the same, independent of the exact opcode.

Even across different instruction classes there are some similarities. For example, all instruction classes, except jump, use the arithmetic-logical unit (ALU) after reading the registers. The memory-reference instructions use the ALU for an address calculation, the arithmetic-logical instructions for the operation execution, and branches for comparison. As we can see, the simplicity and regularity of the instruction set simplifies the implementation by making the execution of many of the instruction classes similar.

After using the ALU, the actions required to complete various instruction classes differ. A memory-reference instruction will need to access the memory either to write data for a store or read data for a load. An arithmetic-logical instruction must write the data from the ALU back into a register. Lastly, for a branch instruction, we may need to change the next instruction address based on the comparison; otherwise the PC should be incremented by 4 to get the address of the next instruction.

Figure 5.1 shows the high-level view of a MIPS implementation, focusing on the various functional units and their interconnection. Although this figure shows most of the flow of data through the processor, it omits two important aspects of instruction execution.

First, in several places, Figure 5.1 shows data going to a particular unit as coming from two different sources. For example, the value written into the PC can come from one of two adders, and the data written into the register file can come from either the ALU or the data memory. In practice, these data lines cannot simply be wired together; we must add an element that chooses from among the multiple sources and steers one of those sources to its destination. This selection is commonly done with a device called a *multiplexor*, although this device might better be called a *data selector*. The multiplexor, which is described in detail in [Appendix B](#), selects from among several inputs based on the setting of its control lines. The control lines are set based primarily on information taken from the instruction being executed.

Second, several of the units must be controlled depending on the type of instruction. For example, the data memory must read on a load and write on a store. The register file must be written on a load and an arithmetic-logical instruction. And, of course, the ALU must perform one of several operations, as we saw in Chapter 3. ([Appendix B](#) describes the detailed logic design of the ALU.) Like the muxes, these operations are directed by control lines that are set on the basis of various fields in the instruction.

Figure 5.2 shows the datapath of Figure 5.1 with the three required multiplexors added, as well as control lines for the major functional units. A control unit that has the instruction as an input is used to determine how to set the control lines for the functional units and two of the multiplexors. The third multiplexor, which determines whether PC + 4 or the branch destination address is written

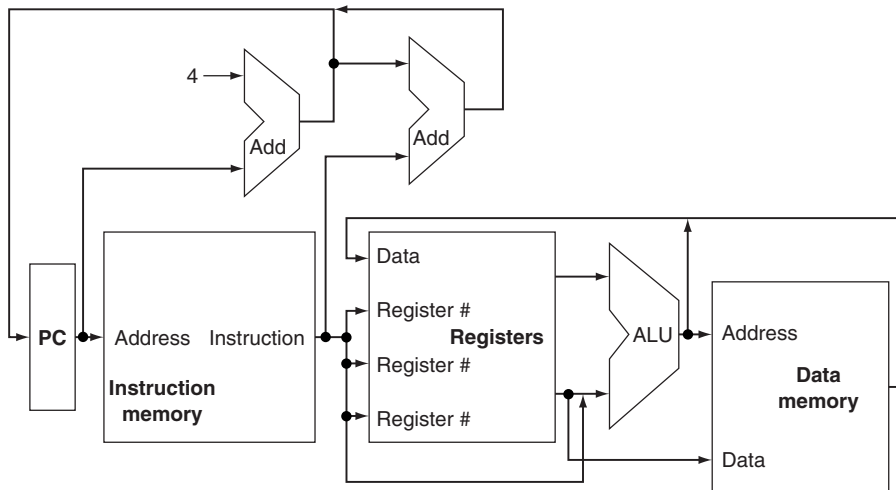

FIGURE 5.1 An abstract view of the implementation of the MIPS subset showing the major functional units and the major connections between them. All instructions start by using the program counter to supply the instruction address to the instruction memory. After the instruction is fetched, the register operands used by an instruction are specified by fields of that instruction. Once the register operands have been fetched, they can be operated on to compute a memory address (for a load or store), to compute an arithmetic result (for an integer arithmetic-logical instruction), or a compare (for a branch). If the instruction is an arithmetic-logical instruction, the result from the ALU must be written to a register. If the operation is a load or store, the ALU result is used as an address to either store a value from the registers or load a value from memory into the registers. The result from the ALU or memory is written back into the register file. Branches require the use of the ALU output to determine the next instruction address, which comes from either the ALU (where the PC and branch offset are summed) or from an adder that increments the current PC by 4. The thick lines interconnecting the functional units represent buses, which consist of multiple signals. The arrows are used to guide the reader in knowing how information flows. Since signal lines may cross, we explicitly show when crossing lines are connected by the presence of a dot where the lines cross.

into the PC, is set based on the zero output of the ALU, which is used to perform the comparison of a `beq` instruction. The regularity and simplicity of the MIPS instruction set means that a simple decoding process can be used to determine how to set the control lines.

In the remainder of the chapter, we refine this view to fill in the details, which requires that we add further functional units, increase the number of connections between units, and, of course, add a control unit to control what actions are taken for different instruction classes. Sections 5.3 and 5.4 describe a simple implementation that uses a single long clock cycle for every instruction and follows the general form of Figures 5.1 and 5.2. In this first design, every instruction begins execution on one clock edge and completes execution on the next clock edge.

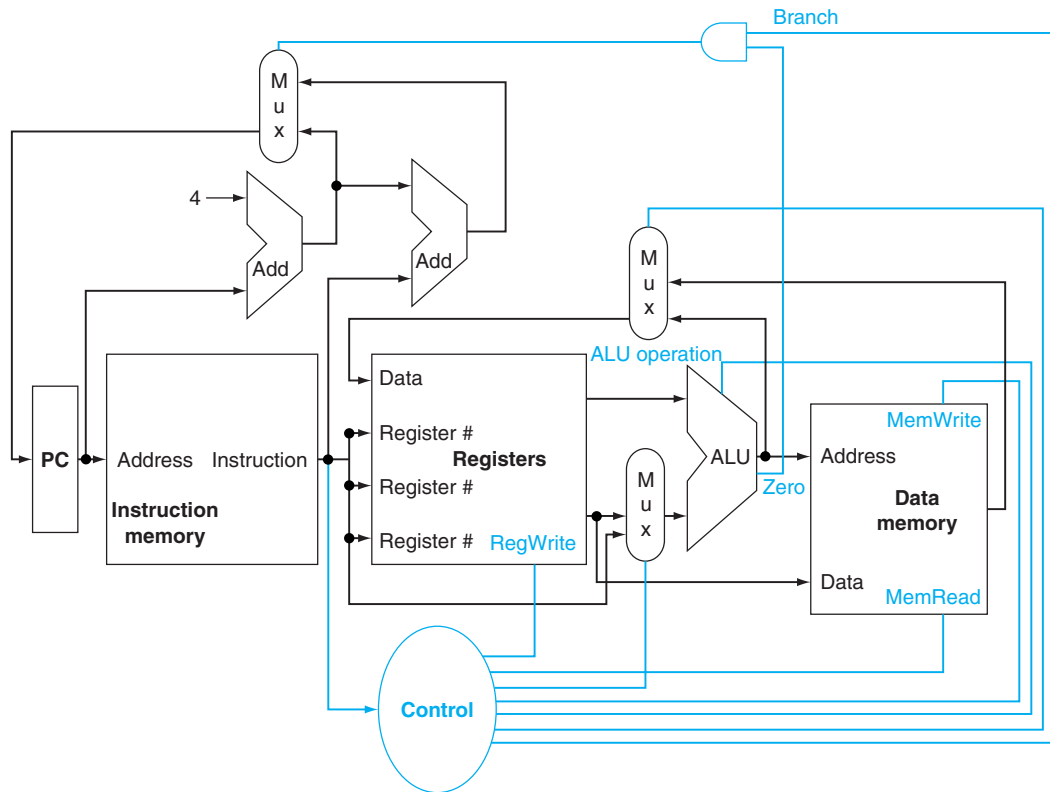

FIGURE 5.2 The basic implementation of the MIPS subset including the necessary multiplexers and control lines. The top multiplexor controls what value replaces the PC ($PC + 4$ or the branch destination address); the multiplexor is controlled by the gate that “ands” together the Zero output of the ALU and a control signal that indicates that the instruction is a branch. The multiplexor whose output returns to the register file is used to steer the output of the ALU (in the case of an arithmetic-logical instruction) or the output of the data memory (in the case of a load) for writing into the register file. Finally, the bottommost multiplexor is used to determine whether the second ALU input is from the registers (for a nonimmediate arithmetic-logical instruction) or from the offset field of the instruction (for an immediate operation, a load or store, or a branch). The added control lines are straightforward and determine the operation performed at the ALU, whether the data memory should read or write, and whether the registers should perform a write operation. The control lines are shown in color to make them easier to see.

While easier to understand, this approach is not practical, since it would be slower than an implementation that allows different instruction classes to take different numbers of clock cycles, each of which could be much shorter. After designing the control for this simple machine, we will look at an implementation that uses multiple clock cycles for each instruction. This multicycle design is used

when we discuss more advanced control concepts, handling exceptions, and the use of hardware design languages in Sections 5.5 through 5.8.

The single-cycle datapath conceptually described in this section *must* have separate instruction and data memories because

1. the format of data and instructions is different in MIPS and hence different memories are needed
2. having separate memories is less expensive
3. the processor operates in one cycle and cannot use a single-ported memory for two different accesses within that cycle

Check Yourself

5.2 Logic Design Conventions

To discuss the design of a machine, we must decide how the logic implementing the machine will operate and how the machine is clocked. This section reviews a few key ideas in digital logic that we will use extensively in this chapter. If you have little or no background in digital logic, you will find it helpful to read through Appendix B before continuing.

The functional units in the MIPS implementation consist of two different types of logic elements: elements that operate on data values and elements that contain state. The elements that operate on data values are all *combinational*, which means that their outputs depend only on the current inputs. Given the same input, a combinational element always produces the same output. The ALU shown in Figure 5.1 and discussed in Chapter 3 and [Appendix B](#) is a combinational element. Given a set of inputs, it always produces the same output because it has no internal storage.

Other elements in the design are not combinational, but instead contain *state*. An element contains state if it has some internal storage. We call these elements **state elements** because, if we pulled the plug on the machine, we could restart it by loading the state elements with the values they contained before we pulled the plug. Furthermore, if we saved and restored the state elements, it would be as if the machine had never lost power. Thus, these state elements completely characterize the machine. In Figure 5.1, the instruction and data memories as well as the registers are all examples of state elements.

A state element has at least two inputs and one output. The required inputs are the data value to be written into the element and the clock, which determines

state element A memory element.

when the data value is written. The output from a state element provides the value that was written in an earlier clock cycle. For example, one of the logically simplest state elements is a D-type flip-flop (see Appendix B), which has exactly these two inputs (a value and a clock) and one output. In addition to flip-flops, our MIPS implementation also uses two other types of state elements: memories and registers, both of which appear in Figure 5.1. The clock is used to determine when the state element should be written; a state element can be read at any time.

Logic components that contain state are also called *sequential* because their outputs depend on both their inputs and the contents of the internal state. For example, the output from the functional unit representing the registers depends both on the register numbers supplied and on what was written into the registers previously. The operation of both the combinational and sequential elements and their construction are discussed in more detail in [Appendix B](#).

We will use the word *asserted* to indicate a signal that is logically high and *assert* to specify that a signal should be driven logically high, and *deassert* or *deasserted* to represent logical low.

Clocking Methodology

A **clocking methodology** defines when signals can be read and when they can be written. It is important to specify the timing of reads and writes because, if a signal is written at the same time it is read, the value of the read could correspond to the old value, the newly written value, or even some mix of the two! Needless to say, computer designs cannot tolerate such unpredictability. A clocking methodology is designed to prevent this circumstance.

For simplicity, we will assume an **edge-triggered** clocking methodology. An edge-triggered clocking methodology means that any values stored in a sequential logic element are updated only on a clock edge. Because only state elements can store a data value, any collection of combinational logic must have its inputs coming from a set of state elements and its outputs written into a set of state elements. The inputs are values that were written in a previous clock cycle, while the outputs are values that can be used in a following clock cycle.

Figure 5.3 shows the two state elements surrounding a block of combinational logic, which operates in a single clock cycle: All signals must propagate from state element 1, through the combinational logic, and to state element 2 in the time of one clock cycle. The time necessary for the signals to reach state element 2 defines the length of the clock cycle.

For simplicity, we do not show a write **control signal** when a state element is written on every active clock edge. In contrast, if a state element is not updated on every clock, then an explicit write control signal is required. Both the clock signal and the write control signal are inputs, and the state element is changed only when the write control signal is asserted and a clock edge occurs.

clocking methodology The approach used to determine when data is valid and stable relative to the clock.

edge-triggered clocking A clocking scheme in which all state changes occur on a clock edge.

control signal A signal used for multiplexor selection or for directing the operation of a functional unit; contrasts with a data signal, which contains information that is operated on by a functional unit.

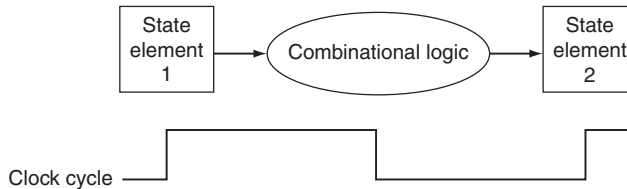

FIGURE 5.3 Combinational logic, state elements, and the clock are closely related. In a synchronous digital system, the clock determines when elements with state will write values into internal storage. Any inputs to a state element must reach a stable value (that is, have reached a value from which they will not change until after the clock edge) before the active clock edge causes the state to be updated. All state elements, including memory, are assumed to be edge-triggered.

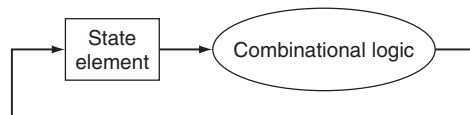

FIGURE 5.4 An edge-triggered methodology allows a state element to be read and written in the same clock cycle without creating a race that could lead to indeterminate data values. Of course, the clock cycle still must be long enough so that the input values are stable when the active clock edge occurs. Feedback cannot occur within 1 clock cycle because of the edge-triggered update of the state element. If feedback were possible, this design could not work properly. Our designs in this chapter and the next rely on the edge-triggered timing methodology and structures like the one shown in this figure.

An edge-triggered methodology allows us to read the contents of a register, send the value through some combinational logic, and write that register in the same clock cycle, as shown in Figure 5.4. It doesn't matter whether we assume that all writes take place on the rising clock edge or on the falling clock edge, since the inputs to the combinational logic block cannot change except on the chosen clock edge. With an edge-triggered timing methodology, there is *no* feedback within a single clock cycle, and the logic in Figure 5.4 works correctly. In [Appendix B](#) we briefly discuss additional timing constraints (such as setup and hold times) as well as other timing methodologies.

Nearly all of these state and logic elements will have inputs and outputs that are 32 bits wide, since that is the width of most of the data handled by the processor. We will make it clear whenever a unit has an input or output that is other than 32 bits in width. The figures will indicate *buses*, which are signals wider than 1 bit, with thicker lines. At times we will want to combine several buses to form a wider bus; for example, we may want to obtain a 32-bit bus by combining two 16-bit

buses. In such cases, labels on the bus lines will make it clear that we are concatenating buses to form a wider bus. Arrows are also added to help clarify the direction of the flow of data between elements. Finally, **color** indicates a control signal as opposed to a signal that carries data; this distinction will become clearer as we proceed through this chapter.

Check Yourself

True or false: Because the register file is both read and written on the same clock cycle, any MIPS datapath using edge-triggered writes must have more than one copy of the register file.

5.3 Building a Datapath

A reasonable way to start a datapath design is to examine the major components required to execute each class of MIPS instruction. Let's start by looking at which **datapath elements** each instruction needs. When we show the datapath elements, we will also show their control signals.

Figure 5.5 shows the first element we need: a memory unit to store the instructions of a program and supply instructions given an address. Figure 5.5 also shows a register, which we call the **program counter (PC)**, that is used to hold the address of the current instruction. Lastly, we will need an adder to increment the PC to the address of the next instruction. This adder, which is combinational, can be built from the ALU we described in Chapter 3 and designed in detail in Appendix B, simply by wiring the control lines so that the control always specifies an add operation. We will draw such an ALU with the label *Add*, as in Figure 5.5, to indicate that it has been permanently made an adder and cannot perform the other ALU functions.

To execute any instruction, we must start by fetching the instruction from memory. To prepare for executing the next instruction, we must also increment the program counter so that it points at the next instruction, 4 bytes later. Figure 5.6 shows how the three elements from Figure 5.5 are combined to form a datapath that fetches instructions and increments the PC to obtain the address of the next sequential instruction.

Now let's consider the R-format instructions (see Figure 2.7 on page 67). They all read two registers, perform an ALU operation on the contents of the registers, and write the result. We call these instructions either *R-type instructions* or *arithmetic-logical instructions* (since they perform arithmetic or logical operations). This instruction class includes `add`, `sub`, `and`, `or`, and `sllt`, which were intro-

datapath element A functional unit used to operate on or hold data within a processor. In the MIPS implementation the datapath elements include the instruction and data memories, the register file, the arithmetic logic unit (ALU), and adders.

program counter (PC) The register containing the address of the instruction in the program being executed

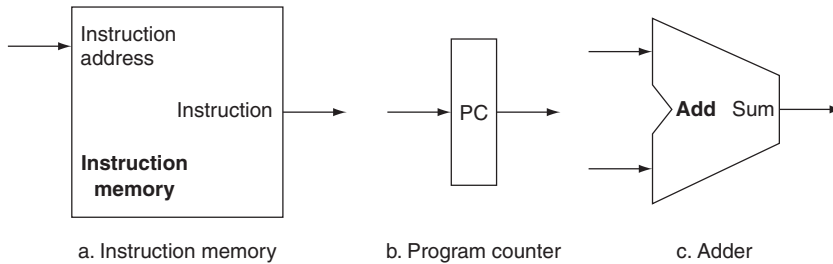

FIGURE 5.5 Two state elements are needed to store and access instructions, and an adder is needed to compute the next instruction address. The state elements are the instruction memory and the program counter. The instruction memory need only provide read access because the datapath does not write instructions. Since the instruction memory only reads, we treat it as combinational logic: the output at any time reflects the contents of the location specified by the address input, and no read control signal is needed. (We will need to write the instruction memory when we load the program; this is not hard to add, and we ignore it for simplicity.) The program counter is a 32-bit register that will be written at the end of every clock cycle and thus does not need a write control signal. The adder is an ALU wired to always perform an add of its two 32-bit inputs and place the result on its output.

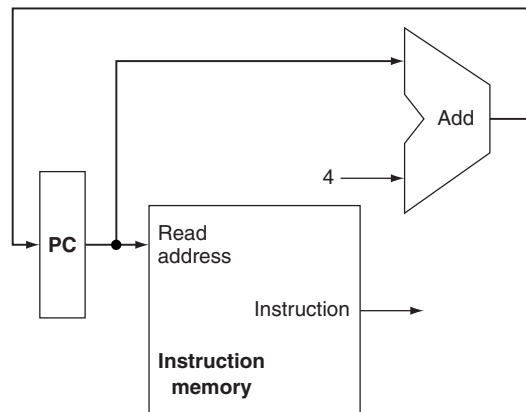

FIGURE 5.6 A portion of the datapath used for fetching instructions and incrementing the program counter. The fetched instruction is used by other parts of the datapath.

duced in Chapter 2. Recall that a typical instance of such an instruction is `add $t1,$t2,$t3`, which reads `$t2` and `$t3` and writes `$t1`.

The processor's 32 general-purpose registers are stored in a structure called a **register file**. A register file is a collection of registers in which any register can be

register file A state element that consists of a set of registers that can be read and written by supplying a register number to be accessed.

read or written by specifying the number of the register in the file. The register file contains the register state of the machine. In addition, we will need an ALU to operate on the values read from the registers.

Because the R-format instructions have three register operands, we will need to read two data words from the register file and write one data word into the register file for each instruction. For each data word to be read from the registers, we need an input to the register file that specifies the register number to be read and an output from the register file that will carry the value that has been read from the registers. To write a data word, we will need two inputs: one to specify the *register number* to be written and one to supply the *data* to be written into the register. The register file always outputs the contents of whatever register numbers are on the Read register inputs. Writes, however, are controlled by the write control signal, which must be asserted for a write to occur at the clock edge. Thus, we need a total of four inputs (three for register numbers and one for data) and two outputs (both for data), as shown in Figure 5.7. The register number inputs are 5 bits wide to specify one of 32 registers ($32 = 2^5$), whereas the data input and two data output buses are each 32 bits wide.

Figure 5.7 shows the ALU, which takes two 32-bit inputs and produces a 32-bit result, as well as a 1-bit signal if the result is 0. The four-bit control signal of the ALU is described in detail in [Appendix B](#); we will review the ALU control shortly when we need to know how to set it.

Next, consider the MIPS load word and store word instructions, which have the general form `lw $t1,offset_value($t2)` or `sw $t1,offset_value($t2)`. These instructions compute a memory address by adding the base register, which is `$t2`, to the 16-bit signed offset field contained in the instruction. If the instruction is a store, the value to be stored must also be read from the register file where it resides in `$t1`. If the instruction is a load, the value read from memory must be written into the register file in the specified register, which is `$t1`. Thus, we will need both the register file and the ALU from Figure 5.7.

In addition, we will need a unit to **sign-extend** the 16-bit offset field in the instruction to a 32-bit signed value, and a data memory unit to read from or write to. The data memory must be written on store instructions; hence, it has both read and write control signals, an address input, as well as an input for the data to be written into memory. Figure 5.8 shows these two elements.

The `beq` instruction has three operands, two registers that are compared for equality, and a 16-bit offset used to compute the **branch target address** relative to the branch instruction address. Its form is `beq $t1,$t2,offset`. To implement this instruction, we must compute the branch target address by adding the sign-extended offset field of the instruction to the PC. There are two details in the definition of branch instructions (see Chapter 2) to which we must pay attention:

sign-extend To increase the size of a data item by replicating the high-order sign bit of the original data item in the high-order bits of the larger, destination data item.

branch target address The address specified in a branch, which becomes the new program counter (PC) if the branch is taken. In the MIPS architecture the branch target is given by the sum of the offset field of the instruction and the address of the instruction following the branch.

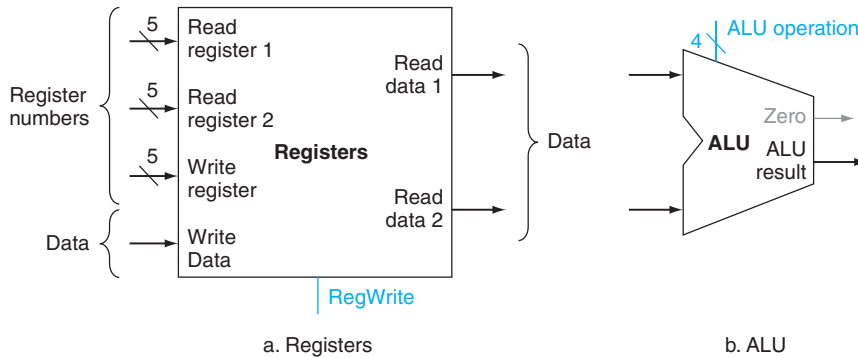

FIGURE 5.7 The two elements needed to implement R-format ALU operations are the register file and the ALU. The register file contains all the registers and has two read ports and one write port. The design of multiported register files is discussed in Section B.8 of Appendix B. The register file always outputs the contents of the registers corresponding to the Read register inputs on the outputs; no other control inputs are needed. In contrast, a register write must be explicitly indicated by asserting the write control signal. Remember that writes are edge-triggered, so that all the write inputs (i.e., the value to be written, the register number, and the write control signal) must be valid at the clock edge. Since writes to the register file are edge-triggered, our design can legally read and write the same register within a clock cycle: the read will get the value written in an earlier clock cycle, while the value written will be available to a read in a subsequent clock cycle. The inputs carrying the register number to the register file are all 5 bits wide, whereas the lines carrying data values are 32 bits wide. The operation to be performed by the ALU is controlled with the ALU operation signal, which will be 4 bits wide, using the ALU designed in [Appendix B](#). We will use the Zero detection output of the ALU shortly to implement branches. The overflow output will not be needed until Section 5.6, when we discuss exceptions; we omit it until then.

- The instruction set architecture specifies that the base for the branch address calculation is the address of the instruction following the branch. Since we compute $PC + 4$ (the address of the next instruction) in the instruction fetch datapath, it is easy to use this value as the base for computing the branch target address.
- The architecture also states that the offset field is shifted left 2 bits so that it is a word offset; this shift increases the effective range of the offset field by a factor of four.

To deal with the latter complication, we will need to shift the offset field by two.

In addition to computing the branch target address, we must also determine whether the next instruction is the instruction that follows sequentially or the instruction at the branch target address. When the condition is true (i.e., the operands are equal), the branch target address becomes the new PC, and we say that the **branch is taken**. If the operands are not equal, the incremented PC should replace the current PC (just as for any other normal instruction); in this case, we say that the **branch is not taken**.

branch taken A branch where the branch condition is satisfied and the program counter (PC) becomes the branch target. All unconditional branches are taken branches.

branch not taken A branch where the branch condition is false and the program counter (PC) becomes the address of the instruction that sequentially follows the branch.

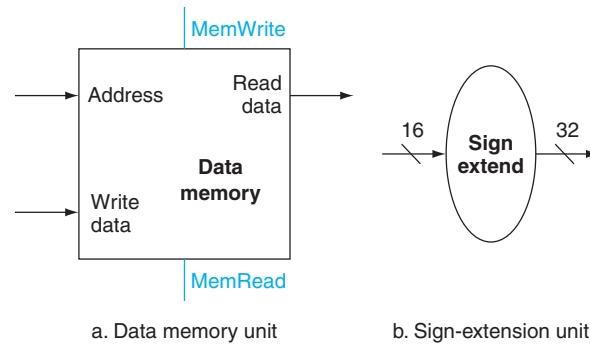

FIGURE 5.8 The two units needed to implement loads and stores, in addition to the register file and ALU of Figure 5.7, are the data memory unit and the sign extension unit. The memory unit is a state element with inputs for the address and the write data, and a single output for the read result. There are separate read and write controls, although only one of these may be asserted on any given clock. The memory unit needs a read signal, since, unlike the register file, reading the value of an invalid address can cause problems, as we will see in Chapter 7. The sign extension unit has a 16-bit input that is sign-extended into a 32-bit result appearing on the output (see Chapter 3). We assume the data memory is edge-triggered for writes. Standard memory chips actually have a write enable signal that is used for writes. Although the write enable is not edge-triggered, our edge-triggered design could easily be adapted to work with real memory chips. See Section B.8 of [Appendix B](#) for a further discussion of how real memory chips work.

Thus, the branch datapath must do two operations: compute the branch target address and compare the register contents. (Branches also affect the instruction fetch portion of the datapath, as we will deal with shortly.) Because of the complexity of handling branches, we show the structure of the datapath segment that handles branches in Figure 5.9. To compute the branch target address, the branch datapath includes a sign extension unit, just like that in Figure 5.8, and an adder. To perform the compare, we need to use the register file shown in Figure 5.7 to supply the two register operands (although we will not need to write into the register file). In addition, the comparison can be done using the ALU we designed in Appendix B. Since that ALU provides an output signal that indicates whether the result was 0, we can send the two register operands to the ALU with the control set to do a subtract. If the Zero signal out of the ALU unit is asserted, we know that the two values are equal. Although the Zero output always signals if the result is 0, we will be using it only to implement the equal test of branches. Later, we will show exactly how to connect the control signals of the ALU for use in the datapath.

The jump instruction operates by replacing the lower 28 bits of the PC with the lower 26 bits of the instruction shifted left by 2 bits. This shift is accomplished simply by concatenating 00 to the jump offset, as described in Chapter 2.

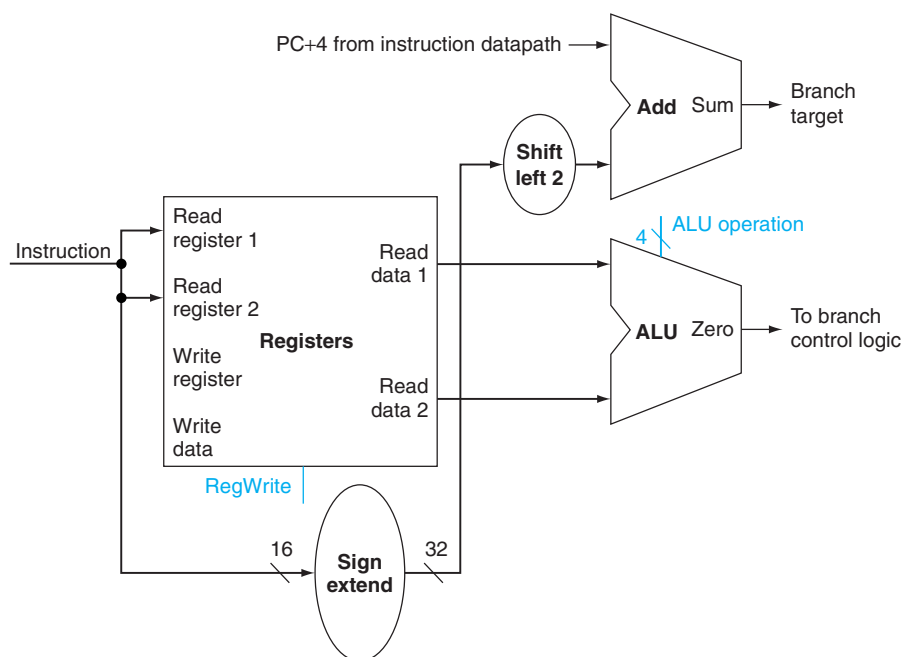

FIGURE 5.9 The datapath for a branch uses the ALU to evaluate the branch condition and a separate adder to compute the branch target as the sum of the incremented PC and the sign-extended, lower 16 bits of the instruction (the branch displacement), shifted left 2 bits. The unit labeled *Shift left 2* is simply a routing of the signals between input and output that adds 00_{two} to the low-order end of the sign-extended offset field; no actual shift hardware is needed, since the amount of the “shift” is constant. Since we know that the offset was sign-extended from 16 bits, the shift will throw away only “sign bits.” Control logic is used to decide whether the incremented PC or branch target should replace the PC, based on the Zero output of the ALU.

Elaboration: In the MIPS instruction set, branches are **delayed**, meaning that the instruction immediately following the branch is always executed, *independent* of whether the branch condition is true or false. When the condition is false, the execution looks like a normal branch. When the condition is true, a delayed branch first executes the instruction immediately following the branch in sequential instruction order before jumping to the specified branch target address. The motivation for delayed branches arises from how pipelining affects branches (see Section 6.6). For simplicity, we ignore delayed branches in this chapter and implement a nondelayed `beq` instruction.

delayed branch A type of branch where the instruction immediately following the branch is always executed, independent of whether the branch condition is true or false.

Creating a Single Datapath

Now that we have examined the datapath components needed for the individual instruction classes, we can combine them into a single datapath and add the control to complete the implementation. The simplest datapath might attempt to execute all instructions in one clock cycle. This means that no datapath resource can be used more than once per instruction, so any element needed more than once must be duplicated. We therefore need a memory for instructions separate from one for data. Although some of the functional units will need to be duplicated, many of the elements can be shared by different instruction flows.

To share a datapath element between two different instruction classes, we may need to allow multiple connections to the input of an element, using a multiplexor and control signal to select among the multiple inputs.

EXAMPLE

Building a Datapath

The operations of arithmetic-logical (or R-type) instructions and the memory instructions datapath are quite similar. The key differences are the following:

- The arithmetic-logical instructions use the ALU with the inputs coming from the two registers. The memory instructions can also use the ALU to do the address calculation, although the second input is the sign-extended 16-bit offset field from the instruction.
- The value stored into a destination register comes from the ALU (for an R-type instruction) or the memory (for a load).

Show how to build a datapath for the operational portion of the memory reference and arithmetic-logical instructions that uses a single register file and a single ALU to handle both types of instructions, adding any necessary multiplexors.

ANSWER

To create a datapath with only a single register file and a single ALU, we must support two different sources for the second ALU input, as well as two different sources for the data stored into the register file. Thus, one multiplexor is placed at the ALU input and another at the data input to the register file. Figure 5.10 shows the operational portion of the combined datapath.

Now we can combine all the pieces to make a simple datapath for the MIPS architecture by adding the datapath for instruction fetch (Figure 5.6 on page 293),

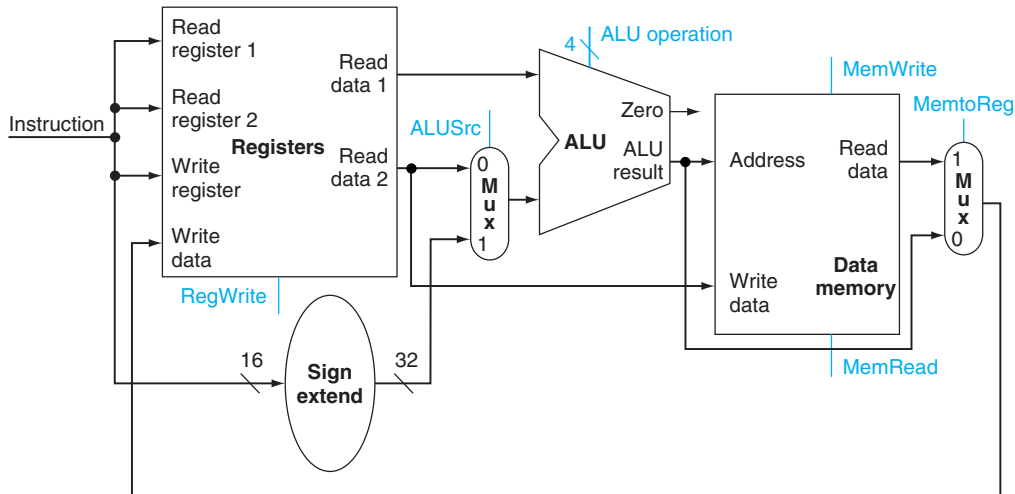

FIGURE 5.10 The datapath for the memory instructions and the R-type instructions. This example shows how a single datapath can be assembled from the pieces in Figures 5.7 and 5.8 by adding multiplexers. Two multiplexers are needed, as described as in the example.

the datapath from R-type and memory instructions (Figure 5.10 on page 299), and the datapath for branches (Figure 5.9 on page 297). Figure 5.11 shows the datapath we obtain by composing the separate pieces. The branch instruction uses the main ALU for comparison of the register operands, so we must keep the adder in Figure 5.9 for computing the branch target address. An additional multiplexer is required to select either the sequentially following instruction address ($PC + 4$) or the branch target address to be written into the PC.

Now that we have completed this simple datapath, we can add the control unit. The control unit must be able to take inputs and generate a write signal for each state element, the selector control for each multiplexer, and the ALU control. The ALU control is different in a number of ways, and it will be useful to design it first before we design the rest of the control unit.

Which of the following is correct for a load instruction?

- MemtoReg should be set to cause the data from memory to be sent to the register file.
- MemtoReg should be set to cause the correct register destination to be sent to the register file.
- We do not care about the setting of MemtoReg.

**Check
Yourself**

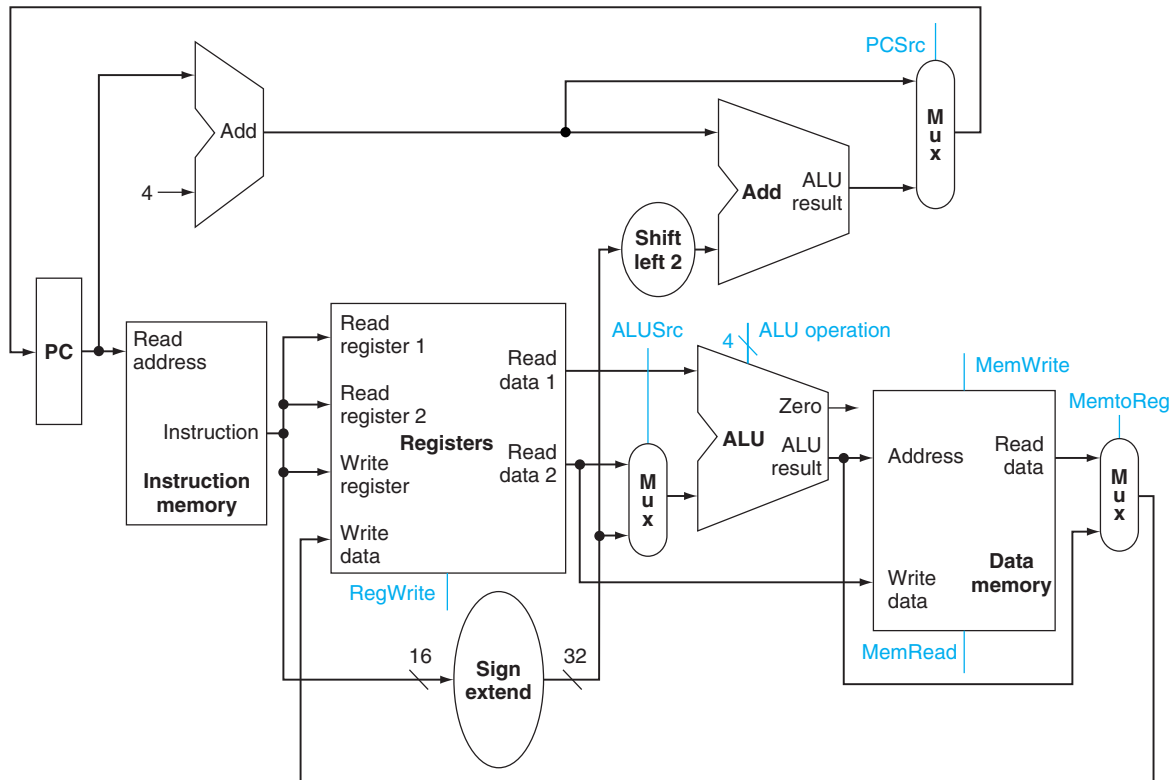

FIGURE 5.11 The simple datapath for the MIPS architecture combines the elements required by different instruction classes. This datapath can execute the basic instructions (load/store word, ALU operations, and branches) in a single clock cycle. An additional multiplexor is needed to integrate branches. The support for jumps will be added later.

5.4 A Simple Implementation Scheme

In this section, we look at what might be thought of as the simplest possible implementation of our MIPS subset. We build this simple implementation using the datapath of the last section and adding a simple control function. This simple implementation covers load word (`lw`), store word (`sw`), branch equal (`beq`), and the arithmetic-logical instructions `add`, `sub`, `and`, `or`, and `set` on less than. We will later enhance the design to include a jump instruction (`j`).

The ALU Control

As can be seen in Appendix B, the ALU has four control inputs. These bits were not encoded; hence, only 6 of the possible 16 possible input combinations are used in this subset. The MIPS ALU in [Appendix B](#) shows the 6 following combinations:

| ALU control lines | Function |
|-------------------|------------------|
| 0000 | AND |
| 0001 | OR |
| 0010 | add |
| 0110 | subtract |
| 0111 | set on less than |
| 1100 | NOR |

Depending on the instruction class, the ALU will need to perform one of these first five functions. (NOR is needed for other parts of the MIPS instruction set.) For load word and store word instructions, we use the ALU to compute the memory address by addition. For the R-type instructions, the ALU needs to perform one of the five actions (AND, OR, subtract, add, or set on less than), depending on the value of the 6-bit funct (or function) field in the low-order bits of the instruction (see Chapter 2). For branch equal, the ALU must perform a subtraction.

We can generate the 4-bit ALU control input using a small control unit that has as inputs the function field of the instruction and a 2-bit control field, which we call ALUOp. ALUOp indicates whether the operation to be performed should be add (00) for loads and stores, subtract (01) for `beq`, or determined by the operation encoded in the funct field (10). The output of the ALU control unit is a 4-bit signal that directly controls the ALU by generating one of the 4-bit combinations shown previously.

In Figure 5.12, we show how to set the ALU control inputs based on the 2-bit ALUOp control and the 6-bit function code. For completeness, the relationship between the ALUOp bits and the instruction opcode is also shown. Later in this chapter we will see how the ALUOp bits are generated from the main control unit.

This style of using multiple levels of decoding—that is, the main control unit generates the ALUOp bits, which then are used as input to the ALU control that generates the actual signals to control the ALU unit—is a common implementation technique. Using multiple levels of control can reduce the size of the main control unit. Using several smaller control units may also potentially increase the speed of the control unit. Such optimizations are important, since the control unit is often performance-critical.

There are several different ways to implement the mapping from the 2-bit ALUOp field and the 6-bit funct field to the three ALU operation control bits.

| Instruction opcode | ALUOp | Instruction operation | Funct field | Desired ALU action | ALU control input |
|--------------------|-------|-----------------------|-------------|--------------------|-------------------|
| LW | 00 | load word | XXXXXX | add | 0010 |
| SW | 00 | store word | XXXXXX | add | 0010 |
| Branch equal | 01 | branch equal | XXXXXX | subtract | 0110 |
| R-type | 10 | add | 100000 | add | 0010 |
| R-type | 10 | subtract | 100010 | subtract | 0110 |
| R-type | 10 | AND | 100100 | and | 0000 |
| R-type | 10 | OR | 100101 | or | 0001 |
| R-type | 10 | set on less than | 101010 | set on less than | 0111 |

FIGURE 5.12 How the ALU control bits are set depends on the ALUOp control bits and the different function codes for the R-type instruction. The opcode, listed in the first column, determines the setting of the ALUOp bits. All the encodings are shown in binary. Notice that when the ALUOp code is 00 or 01, the desired ALU action does not depend on the function code field; in this case, we say that we “don’t care” about the value of the function code, and the funct field is shown as XXXXXX. When the ALUOp value is 10, then the function code is used to set the ALU control input.

| ALUOp | | Funct field | | | | | | Operation |
|--------|--------|-------------|----|----|----|----|----|-----------|
| ALUOp1 | ALUOp0 | F5 | F4 | F3 | F2 | F1 | F0 | |
| 0 | 0 | X | X | X | X | X | X | 0010 |
| X | 1 | X | X | X | X | X | X | 0110 |
| 1 | X | X | X | 0 | 0 | 0 | 0 | 0010 |
| 1 | X | X | X | 0 | 0 | 1 | 0 | 0110 |
| 1 | X | X | X | 0 | 1 | 0 | 0 | 0000 |
| 1 | X | X | X | 0 | 1 | 0 | 1 | 0001 |
| 1 | X | X | X | 1 | 0 | 1 | 0 | 0111 |

FIGURE 5.13 The truth table for the three ALU control bits (called Operation). The inputs are the ALUOp and function code field. Only the entries for which the ALU control is asserted are shown. Some don’t-care entries have been added. For example, the ALUOp does not use the encoding 11, so the truth table can contain entries 1X and X1, rather than 10 and 01. Also, when the function field is used, the first two bits (F5 and F4) of these instructions are always 10, so they are don’t-care terms and are replaced with XX in the truth table.

Because only a small number of the 64 possible values of the function field are of interest and the function field is used only when the ALUOp bits equal 10, we can use a small piece of logic that recognizes the subset of possible values and causes the correct setting of the ALU control bits.

As a step in designing this logic, it is useful to create a truth table for the interesting combinations of the function code field and the ALUOp bits, as we’ve done in Figure 5.13; this truth table shows how the 3-bit ALU control is set depending

on these two input fields. Since the full truth table is very large ($2^8 = 256$ entries) and we don't care about the value of the ALU control for many of these input combinations, we show only the truth table entries for which the ALU control must have a specific value. Throughout this chapter, we will use this practice of showing only the truth table entries that must be asserted and not showing those that are all zero or don't care. (This practice has a disadvantage, which we discuss in Section C.2 of Appendix C.)

Because in many instances we do not care about the values of some of the inputs and to keep the tables compact, we also include **don't-care terms**. A don't-care term in this truth table (represented by an X in an input column) indicates that the output does not depend on the value of the input corresponding to that column. For example, when the ALUOp bits are 00, as in the first line of the table in Figure 5.13, we always set the ALU control to 010, independent of the function code. In this case, then, the function code inputs will be don't cares in this line of the truth table. Later, we will see examples of another type of don't-care term. If you are unfamiliar with the concept of don't-care terms, see Appendix B for more information.

Once the truth table has been constructed, it can be optimized and then turned into gates. This process is completely mechanical. Thus, rather than show the final steps here, we describe the process and the result in Section C.2 of Appendix C.

Designing the Main Control Unit

Now that we have described how to design an ALU that uses the function code and a 2-bit signal as its control inputs, we can return to looking at the rest of the control. To start this process, let's identify the fields of an instruction and the control lines that are needed for the datapath we constructed in Figure 5.11 on page 300. To understand how to connect the fields of an instruction to the datapath, it is useful to review the formats of the three instruction classes: the R-type, branch, and load/store instructions. Figure 5.14 shows these formats.

There are several major observations about this instruction format that we will rely on:

- The op field, also called the **opcode**, is always contained in bits 31:26. We will refer to this field as Op[5:0].
- The two registers to be read are always specified by the rs and rt fields, at positions 25:21 and 20:16. This is true for the R-type instructions, branch equal, and for store.
- The base register for load and store instructions is always in bit positions 25:21 (rs).

don't-care term An element of a logical function in which the output does not depend on the values of all the inputs. Don't-care terms may be specified in different ways.

opcode The field that denotes the operation and format of an instruction.

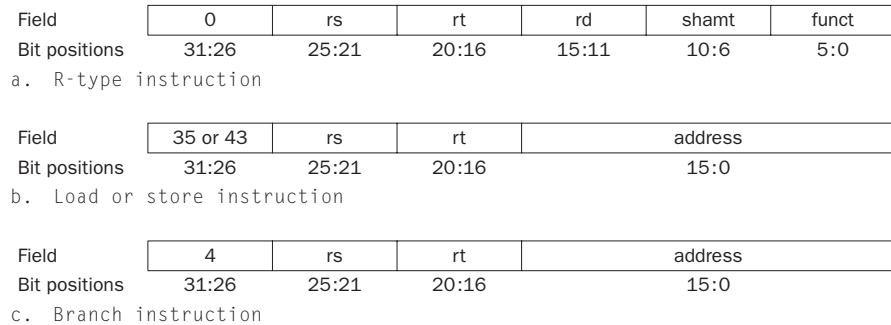

FIGURE 5.14 The three instruction classes (R-type, load and store, and branch) use two different instruction formats. The jump instructions use another format, which we will discuss shortly. (a) Instruction format for R-format instructions, which all have an opcode of 0. These instructions have three register operands: *rs*, *rt*, and *rd*. Fields *rs* and *rt* are sources, and *rd* is the destination. The ALU function is in the *funct* field and is decoded by the ALU control design in the previous section. The R-type instructions that we implement are *add*, *sub*, *and*, *or*, and *slt*. The *shamt* field is used only for shifts; we will ignore it in this chapter. (b) Instruction format for load (opcode = 35_{ten}) and store (opcode = 43_{ten}) instructions. The register *rs* is the base register that is added to the 16-bit address field to form the memory address. For loads, *rt* is the destination register for the loaded value. For stores, *rt* is the source register whose value should be stored into memory. (c) Instruction format for branch equal (opcode = 4). The registers *rs* and *rt* are the source registers that are compared for equality. The 16-bit address field is sign-extended, shifted, and added to the PC to compute the branch target address.

- The 16-bit offset for branch equal, load, and store is always in positions 15:0.
- The destination register is in one of two places. For a load it is in bit positions 20:16 (*rt*), while for an R-type instruction it is in bit positions 15:11 (*rd*). Thus we will need to add a multiplexor to select which field of the instruction is used to indicate the register number to be written.

Using this information, we can add the instruction labels and extra multiplexor (for the Write register number input of the register file) to the simple datapath. Figure 5.15 shows these additions plus the ALU control block, the write signals for state elements, the read signal for the data memory, and the control signals for the multiplexors. Since all the multiplexors have two inputs, they each require a single control line.

Figure 5.15 shows seven single-bit control lines plus the 2-bit ALUOp control signal. We have already defined how the ALUOp control signal works, and it is useful to define what the seven other control signals do informally before we determine how to set these control signals during instruction execution. Figure 5.16 describes the function of these seven control lines.

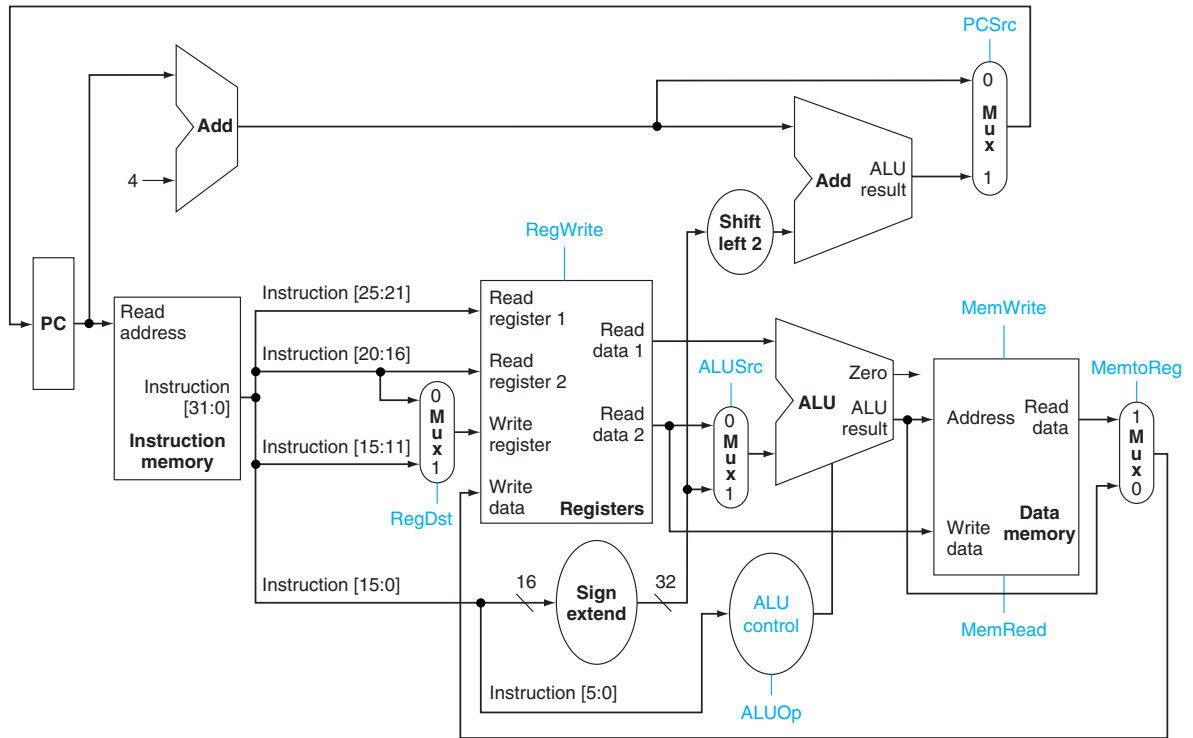

FIGURE 5.15 The datapath of Figure 5.12 with all necessary multiplexors and all control lines identified. The control lines are shown in color. The ALU control block has also been added. The PC does not require a write control, since it is written once at the end of every clock cycle; the branch control logic determines whether it is written with the incremented PC or the branch target address.

Now that we have looked at the function of each of the control signals, we can look at how to set them. The control unit can set all but one of the control signals based solely on the opcode field of the instruction. The PCSrc control line is the exception. That control line should be set if the instruction is branch on equal (a decision that the control unit can make) *and* the Zero output of the ALU, which is used for equality comparison, is true. To generate the PCSrc signal, we will need to AND together a signal from the control unit, which we call *Branch*, with the Zero signal out of the ALU.

These nine control signals (seven from Figure 5.16 and two for ALUOp) can now be set on the basis of six input signals to the control unit, which are the opcode bits. Figure 5.17 shows the datapath with the control unit and the control signals.

| Signal name | Effect when deasserted | Effect when asserted |
|-------------|--|---|
| RegDst | The register destination number for the Write register comes from the rt field (bits 20:16). | The register destination number for the Write register comes from the rd field (bits 15:11). |
| RegWrite | None. | The register on the Write register input is written with the value on the Write data input. |
| ALUSrc | The second ALU operand comes from the second register file output (Read data 2). | The second ALU operand is the sign-extended, lower 16 bits of the instruction. |
| PCSrc | The PC is replaced by the output of the adder that computes the value of PC + 4. | The PC is replaced by the output of the adder that computes the branch target. |
| MemRead | None. | Data memory contents designated by the address input are put on the Read data output. |
| MemWrite | None. | Data memory contents designated by the address input are replaced by the value on the Write data input. |
| MemtoReg | The value fed to the register Write data input comes from the ALU. | The value fed to the register Write data input comes from the data memory. |

FIGURE 5.16 The effect of each of the seven control signals. When the 1-bit control to a two-way multiplexor is asserted, the multiplexor selects the input corresponding to 1. Otherwise, if the control is deasserted, the multiplexor selects the 0 input. Remember that the state elements all have the clock as an implicit input and that the clock is used in controlling writes. The clock is never gated externally to a state element, since this can create timing problems. (See [Appendix B](#) for further discussion of this problem.)

Before we try to write a set of equations or a truth table for the control unit, it will be useful to try to define the control function informally. Because the setting of the control lines depends only on the opcode, we define whether each control signal should be 0, 1, or don't care (X), for each of the opcode values. Figure 5.18 defines how the control signals should be set for each opcode; this information follows directly from Figures 5.12, 5.16, and 5.17.

Operation of the Datapath

With the information contained in Figures 5.16 and 5.18, we can design the control unit logic, but before we do that, let's look at how each instruction uses the datapath. In the next few figures, we show the flow of three different instruction classes through the datapath. The asserted control signals and active datapath elements are highlighted in each of these. Note that a multiplexor whose control is 0 has a definite action, even if its control line is not highlighted. Multiple-bit control signals are highlighted if any constituent signal is asserted.

Figure 5.19 shows the operation of the datapath for an R-type instruction, such as `add $t1, $t2, $t3`. Although everything occurs in 1 clock cycle, we can think of four steps to execute the instruction; these steps are ordered by the flow of information:

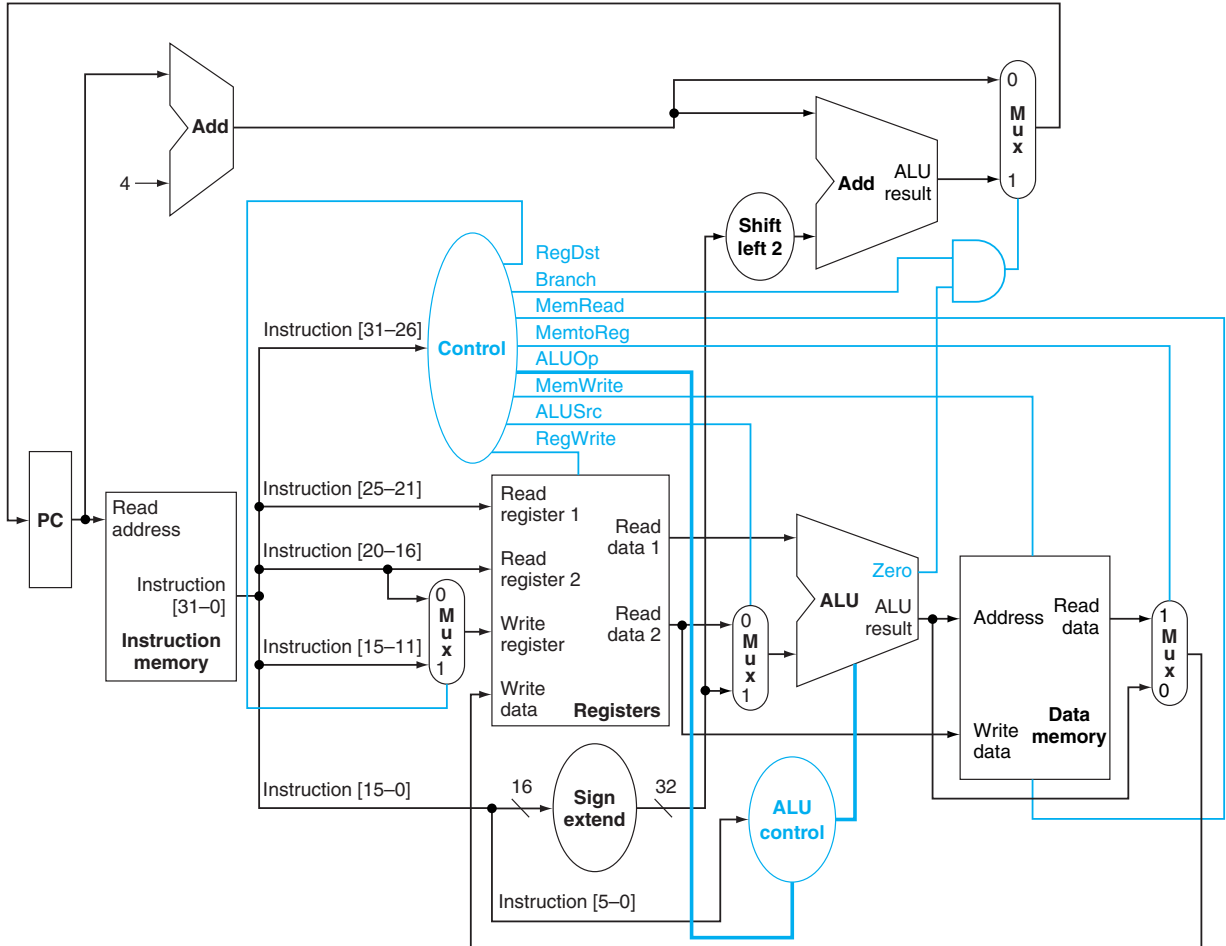

FIGURE 5.17 The simple datapath with the control unit. The input to the control unit is the 6-bit opcode field from the instruction. The outputs of the control unit consist of three 1-bit signals that are used to control multiplexors (RegDst, ALUSrc, and MemtoReg), three signals for controlling reads and writes in the register file and data memory (RegWrite, MemRead, and MemWrite), a 1-bit signal used in determining whether to possibly branch (Branch), and a 2-bit control signal for the ALU (ALUSrc). An AND gate is used to combine the branch control signal and the Zero output from the ALU; the AND gate output controls the selection of the next PC. Notice that PCSrc is now a derived signal, rather than one coming directly from the control unit. Thus we drop the signal name in subsequent figures.

| Instruction | RegDst | ALUSrc | Memto-Reg | Reg Write | Mem Read | Mem Write | Branch | ALUOp1 | ALUOp0 |
|-------------|--------|--------|-----------|-----------|----------|-----------|--------|--------|--------|
| R-format | 1 | 0 | 0 | 1 | 0 | 0 | 0 | 1 | 0 |
| lw | 0 | 1 | 1 | 1 | 1 | 0 | 0 | 0 | 0 |
| sw | X | 1 | X | 0 | 0 | 1 | 0 | 0 | 0 |
| beq | X | 0 | X | 0 | 0 | 0 | 1 | 0 | 1 |

FIGURE 5.18 The setting of the control lines is completely determined by the opcode fields of the instruction. The first row of the table corresponds to the R-format instructions (`add`, `sub`, `and`, `or`, and `sllt`). For all these instructions, the source register fields are `rs` and `rt`, and the destination register field is `rd`; this defines how the signals `ALUSrc` and `RegDst` are set. Furthermore, an R-type instruction writes a register (`RegWrite = 1`), but neither reads nor writes data memory. When the Branch control signal is 0, the PC is unconditionally replaced with `PC + 4`; otherwise, the PC is replaced by the branch target if the Zero output of the ALU is also high. The `ALUOp` field for R-type instructions is set to 10 to indicate that the ALU control should be generated from the `funct` field. The second and third rows of this table give the control signal settings for `lw` and `sw`. These `ALUSrc` and `ALUOp` fields are set to perform the address calculation. The `MemRead` and `MemWrite` are set to perform the memory access. Finally, `RegDst` and `RegWrite` are set for a load to cause the result to be stored into the `rt` register. The branch instruction is similar to an R-format operation, since it sends the `rs` and `rt` registers to the ALU. The `ALUOp` field for branch is set for a subtract (`ALU control = 01`), which is used to test for equality. Notice that the `MemtoReg` field is irrelevant when the `RegWrite` signal is 0: since the register is not being written, the value of the data on the register data write port is not used. Thus, the entry `MemtoReg` in the last two rows of the table is replaced with X for don't care. Don't cares can also be added to `RegDst` when `RegWrite` is 0. This type of don't care must be added by the designer, since it depends on knowledge of how the datapath works.

1. The instruction is fetched, and the PC is incremented.
2. Two registers, `$t2` and `$t3`, are read from the register file, and the main control unit computes the setting of the control lines during this step also.
3. The ALU operates on the data read from the register file, using the function code (bits 5:0, which is the `funct` field, of the instruction) to generate the ALU function.
4. The result from the ALU is written into the register file using bits 15:11 of the instruction to select the destination register (`$t1`).

Similarly, we can illustrate the execution of a load word, such as

```
lw $t1, offset($t2)
```

in a style similar to Figure 5.19. Figure 5.20 on page 310 shows the active functional units and asserted control lines for a load. We can think of a load instruction as operating in five steps (similar to the R-type executed in four):

1. An instruction is fetched from the instruction memory, and the PC is incremented.
2. A register (`$t2`) value is read from the register file.
3. The ALU computes the sum of the value read from the register file and the sign-extended, lower 16 bits of the instruction (`offset`).
4. The sum from the ALU is used as the address for the data memory.

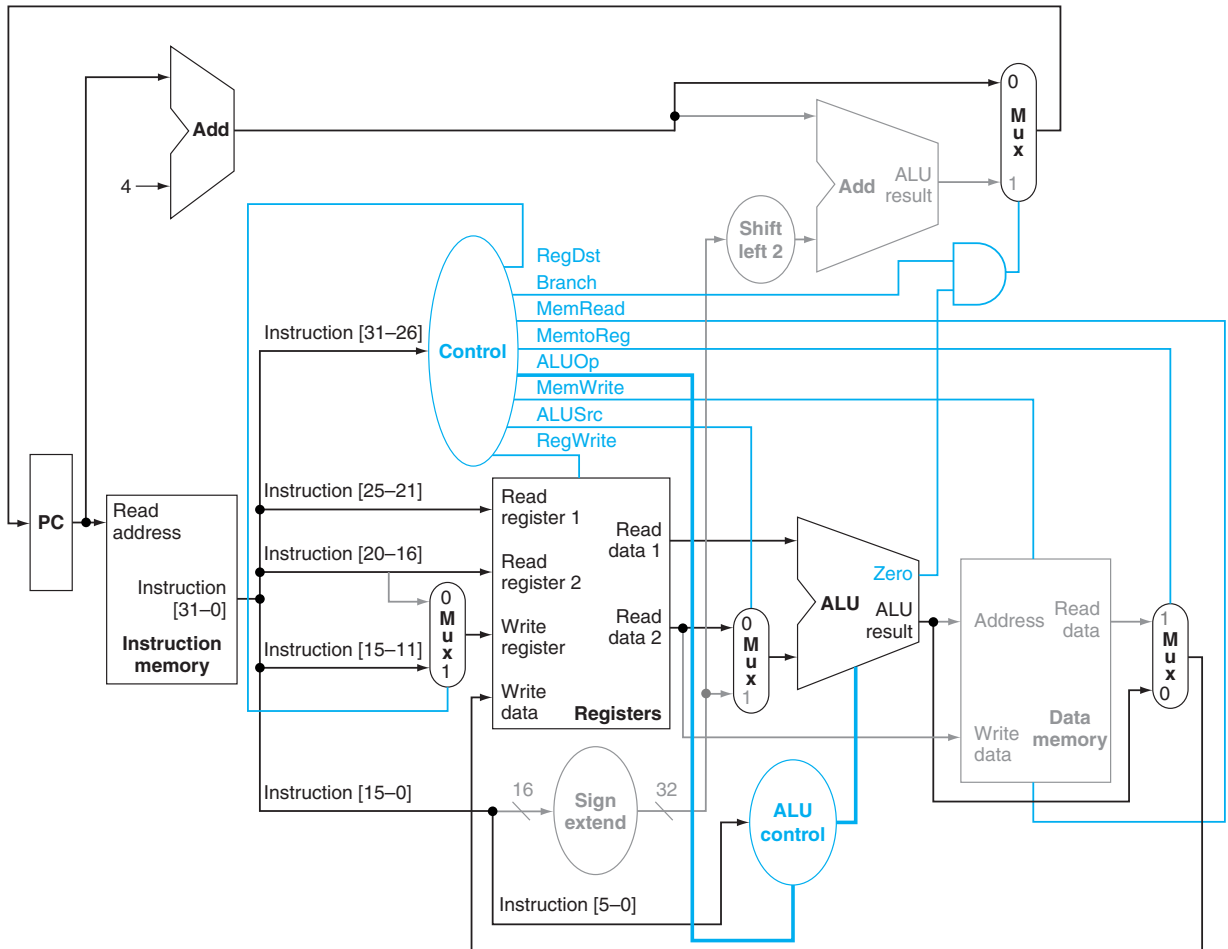

FIGURE 5.19 The datapath in operation for an R-type instruction such as `add $t1, $t2, $t3`. The control lines, datapath units, and connections that are active are highlighted.

5. The data from the memory unit is written into the register file; the register destination is given by bits 20:16 of the instruction (`$t1`).

Finally, we can show the operation of the branch-on-equal instruction, such as `beq $t1, $t2, offset`, in the same fashion. It operates much like an R-format

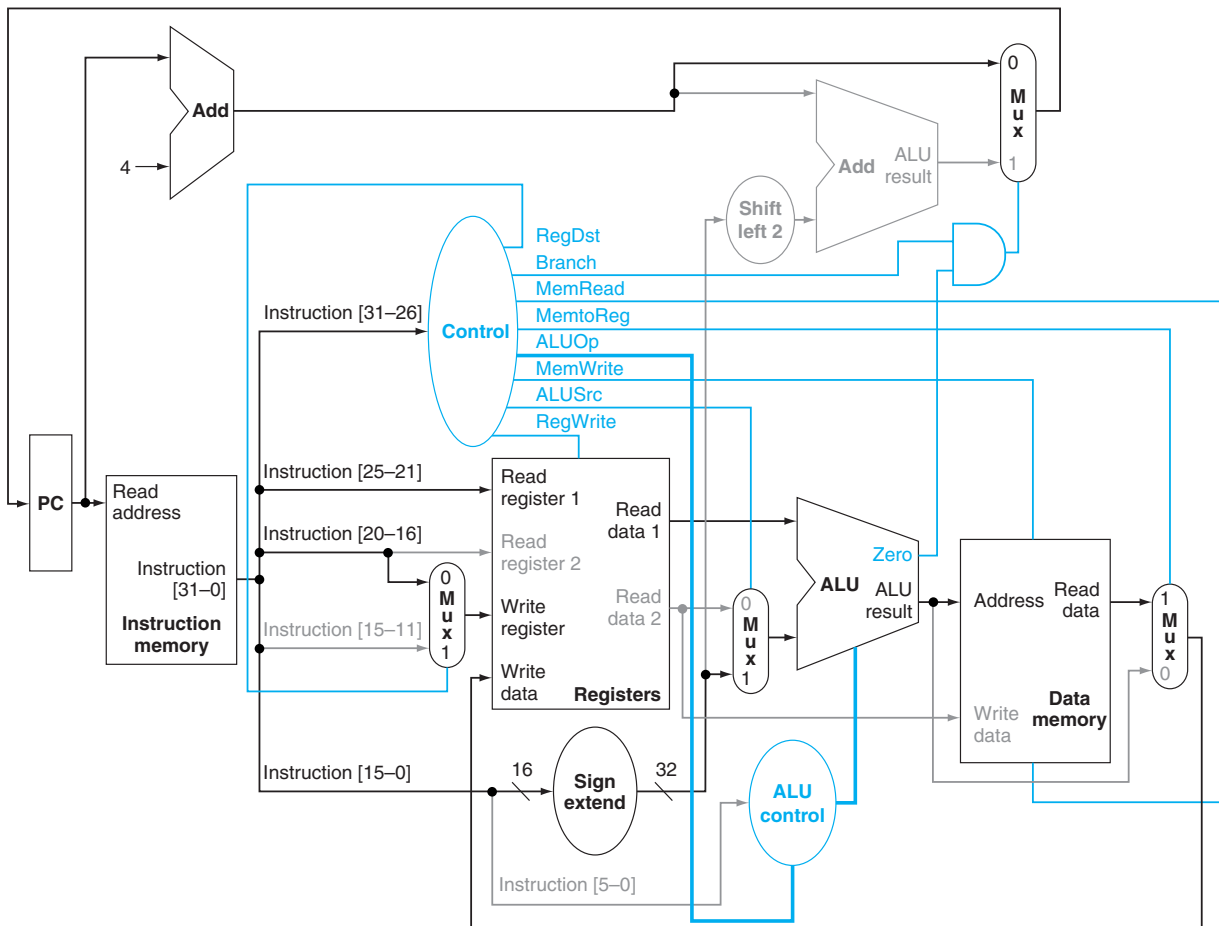

FIGURE 5.20 The datapath in operation for a load instruction. The control lines, datapath units, and connections that are active are highlighted. A store instruction would operate very similarly. The main difference would be that the memory control would indicate a write rather than a read, the second register value read would be used for the data to store, and the operation of writing the data memory value to the register file would not occur.

instruction, but the ALU output is used to determine whether the PC is written with $PC + 4$ or the branch target address. Figure 5.21 shows the four steps in execution:

1. An instruction is fetched from the instruction memory, and the PC is incremented.
2. Two registers, $\$t1$ and $\$t2$, are read from the register file.

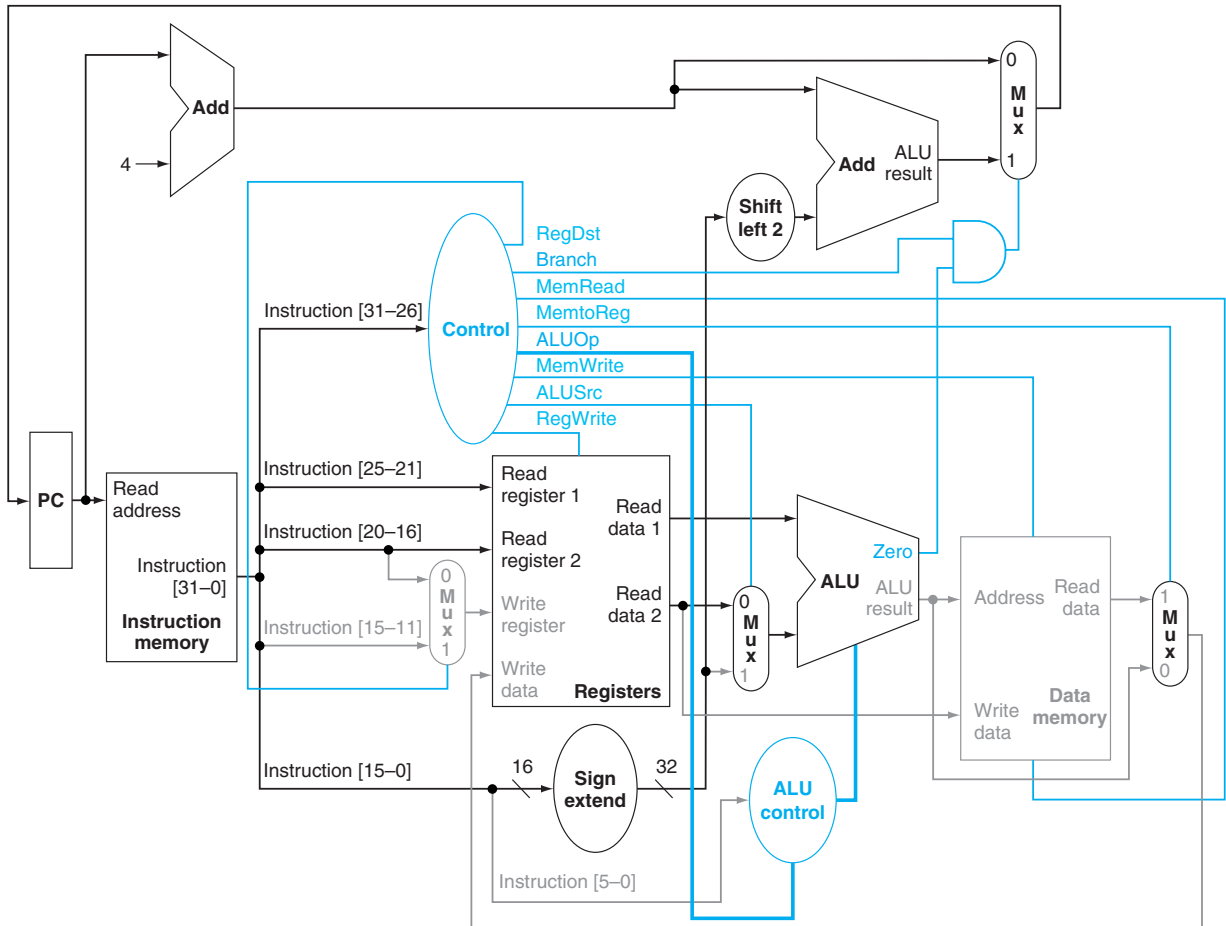

FIGURE 5.21 The datapath in operation for a branch equal instruction. The control lines, datapath units, and connections that are active are highlighted. After using the register file and ALU to perform the compare, the Zero output is used to select the next program counter from between the two candidates.

3. The ALU performs a subtract on the data values read from the register file. The value of $PC + 4$ is added to the sign-extended, lower 16 bits of the instruction (*offset*) shifted left by two; the result is the branch target address.
4. The Zero result from the ALU is used to decide which adder result to store into the PC.

In the next section, we will examine machines that are truly sequential, namely, those in which each of these steps is a distinct clock cycle.

Finalizing the Control

Now that we have seen how the instructions operate in steps, let's continue with the control implementation. The control function can be precisely defined using the contents of Figure 5.18 on page 308. The outputs are the control lines, and the input is the 6-bit opcode field, Op [5:0]. Thus, we can create a truth table for each of the outputs based on the binary encoding of the opcodes.

Figure 5.22 shows the logic in the control unit as one large truth table that combines all the outputs and that uses the opcode bits as inputs. It completely specifies the control function, and we can implement it directly in gates in an automated fashion. We show this final step in Section C.2 in [Appendix C](#).

| Input or output | Signal name | R-format | lw | sw | beq |
|-----------------|-------------|----------|----|----|-----|
| Inputs | Op5 | 0 | 1 | 1 | 0 |
| | Op4 | 0 | 0 | 0 | 0 |
| | Op3 | 0 | 0 | 1 | 0 |
| | Op2 | 0 | 0 | 0 | 1 |
| | Op1 | 0 | 1 | 1 | 0 |
| | Op0 | 0 | 1 | 1 | 0 |
| Outputs | RegDst | 1 | 0 | X | X |
| | ALUSrc | 0 | 1 | 1 | 0 |
| | MemtoReg | 0 | 1 | X | X |
| | RegWrite | 1 | 1 | 0 | 0 |
| | MemRead | 0 | 1 | 0 | 0 |
| | MemWrite | 0 | 0 | 1 | 0 |
| | Branch | 0 | 0 | 0 | 1 |
| | ALUOp1 | 1 | 0 | 0 | 0 |
| | ALUOp0 | 0 | 0 | 0 | 1 |

single-cycle implementation Also called single clock cycle implementation. An implementation in which an instruction is executed in one clock cycle.

FIGURE 5.22 The control function for the simple single-cycle implementation is completely specified by this truth table. The top half of the table gives the combinations of input signals that correspond to the four opcodes that determine the control output settings. (Remember that Op [5:0] corresponds to bits 31:26 of the instruction, which is the op field.) The bottom portion of the table gives the outputs. Thus, the output RegWrite is asserted for two different combinations of the inputs. If we consider only the four opcodes shown in this table, then we can simplify the truth table by using don't cares in the input portion. For example, we can detect an R-format instruction with the expression $\overline{\text{Op5}} \cdot \overline{\text{Op2}}$, since this is sufficient to distinguish the R-format instructions from lw, sw, and beq. We do not take advantage of this simplification, since the rest of the MIPS opcodes are used in a full implementation.

Now, let's add the jump instruction to show how the basic datapath and control can be extended to handle other instructions in the instruction set.

Implementing Jumps

Figure 5.17 on page 307 shows the implementation of many of the instructions we looked at in Chapter 2. One class of instructions missing is that of the jump instruction. Extend the datapath and control of Figure 5.17 to include the jump instruction. Describe how to set any new control lines.

EXAMPLE

The jump instruction looks somewhat like a branch instruction but computes the target PC differently and is not conditional. Like a branch, the low-order 2 bits of a jump address are always 00_{two} . The next lower 26 bits of this 32-bit address come from the 26-bit immediate field in the instruction, as shown in Figure 5.23. The upper 4 bits of the address that should replace the PC come from the PC of the jump instruction plus 4. Thus, we can implement a jump by storing into the PC the concatenation of

ANSWER

- the upper 4 bits of the current PC + 4 (these are bits 31:28 of the sequentially following instruction address)
- the 26-bit immediate field of the jump instruction
- the bits 00_{two}

Figure 5.24 shows the addition of the control for jump added to Figure 5.17. An additional multiplexor is used to select the source for the new PC value, which is either the incremented PC ($PC + 4$), the branch target PC, or the jump target PC. One additional control signal is needed for the additional multiplexor. This control signal, called *Jump*, is asserted only when the instruction is a jump—that is, when the opcode is 2.



FIGURE 5.23 Instruction format for the jump instruction (opcode = 2). The destination address for a jump instruction is formed by concatenating the upper 4 bits of the current PC + 4 to the 26-bit address field in the jump instruction and adding 00 as the 2 low-order bits.

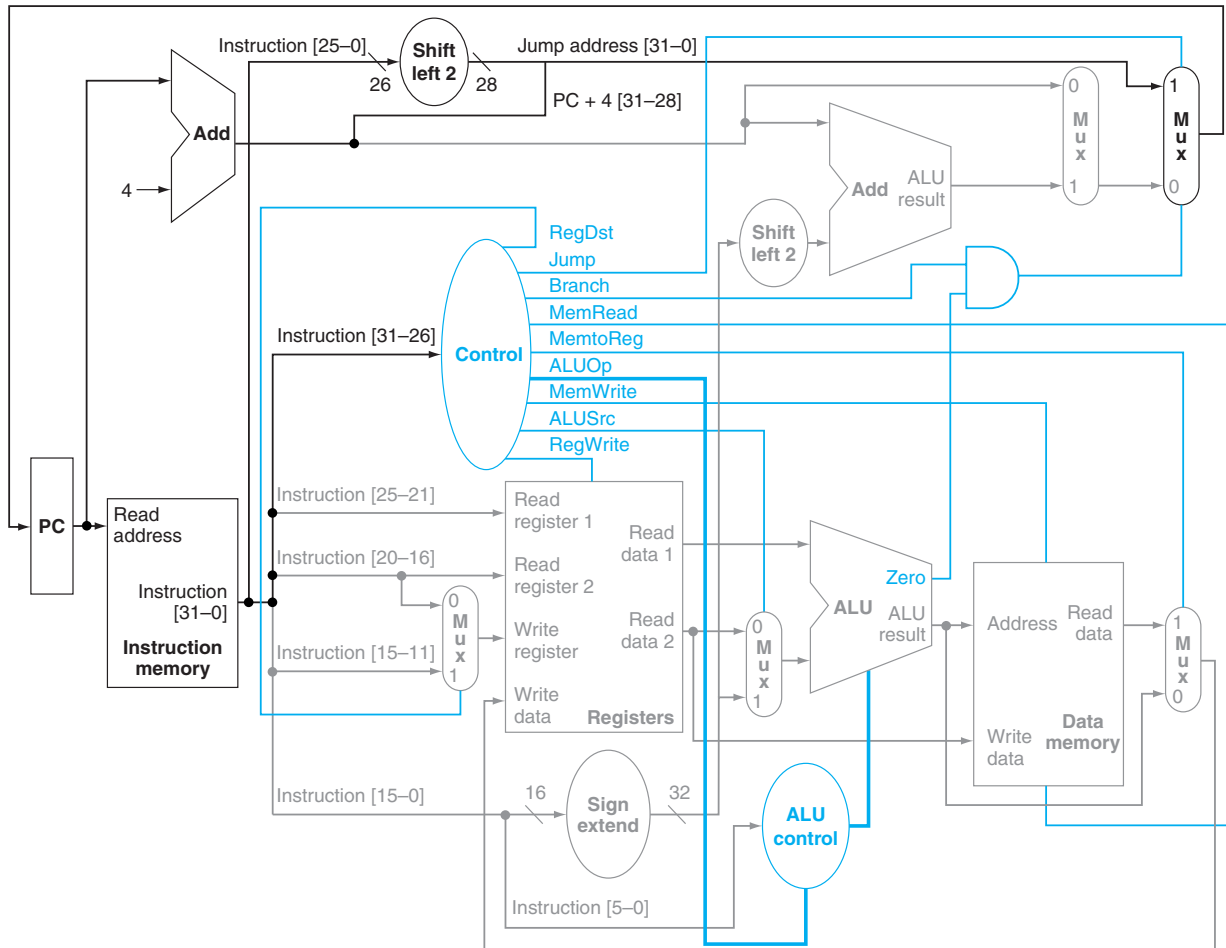

FIGURE 5.24 The simple control and datapath are extended to handle the jump instruction. An additional multiplexor (at the upper right) is used to choose between the jump target and either the branch target or the sequential instruction following this one. This multiplexor is controlled by the jump control signal. The jump target address is obtained by shifting the lower 26 bits of the jump instruction left 2 bits, effectively adding 00 as the low-order bits, and then concatenating the upper 4 bits of $PC + 4$ as the high-order bits, thus yielding a 32-bit address.

Why a Single-Cycle Implementation Is Not Used Today

Although the single-cycle design will work correctly, it would not be used in modern designs because it is inefficient. To see why this is so, notice that the clock cycle must have the same length for every instruction in this single-cycle design, and the CPI

(see Chapter 4) will therefore be 1. Of course, the clock cycle is determined by the longest possible path in the machine. This path is almost certainly a load instruction, which uses five functional units in series: the instruction memory, the register file, the ALU, the data memory, and the register file. Although the CPI is 1, the overall performance of a single-cycle implementation is not likely to be very good, since several of the instruction classes could fit in a shorter clock cycle.

Performance of Single-Cycle Machines

Assume that the operation times for the major functional units in this implementation are the following:

- Memory units: 200 picoseconds (ps)
- ALU and adders: 100 ps
- Register file (read or write): 50 ps

Assuming that the multiplexors, control unit, PC accesses, sign extension unit, and wires have no delay, which of the following implementations would be faster and by how much?

1. An implementation in which every instruction operates in 1 clock cycle of a fixed length.
2. An implementation where every instruction executes in 1 clock cycle using a variable-length clock, which for each instruction is only as long as it needs to be. (Such an approach is not terribly practical, but it will allow us to see what is being sacrificed when all the instructions must execute in a single clock of the same length.)

To compare the performance, assume the following instruction mix: 25% loads, 10% stores, 45% ALU instructions, 15% branches, and 5% jumps.

Let's start by comparing the CPU execution times. Recall from Chapter 4 that

$$\text{CPU execution time} = \text{Instruction count} \times \text{CPI} \times \text{Clock cycle time}$$

Since CPI must be 1, we can simplify this to

$$\text{CPU execution time} = \text{Instruction count} \times \text{Clock cycle time}$$

EXAMPLE

ANSWER

We need only find the clock cycle time for the two implementations, since the instruction count and CPI are the same for both implementations. The critical path for the different instruction classes is as follows:

| Instruction class | Functional units used by the instruction class | | | | |
|-------------------|--|-----------------|-----|-----------------|-----------------|
| R-type | Instruction fetch | Register access | ALU | Register access | |
| Load word | Instruction fetch | Register access | ALU | Memory access | Register access |
| Store word | Instruction fetch | Register access | ALU | Memory access | |
| Branch | Instruction fetch | Register access | ALU | | |
| Jump | Instruction fetch | | | | |

Using these critical paths, we can compute the required length for each instruction class:

| Instruction class | Instruction memory | Register read | ALU operation | Data memory | Register write | Total |
|-------------------|--------------------|---------------|---------------|-------------|----------------|--------|
| R-type | 200 | 50 | 100 | 0 | 50 | 400 ps |
| Load word | 200 | 50 | 100 | 200 | 50 | 600 ps |
| Store word | 200 | 50 | 100 | 200 | | 550 ps |
| Branch | 200 | 50 | 100 | 0 | | 350 ps |
| Jump | 200 | | | | | 200 ps |

The clock cycle for a machine with a single clock for all instructions will be determined by the longest instruction, which is 600 ps. (This timing is approximate, since our timing model is quite simplistic. In reality, the timing of modern digital systems is complex.)

A machine with a variable clock will have a clock cycle that varies between 200 ps and 600 ps. We can find the average clock cycle length for a machine with a variable-length clock using the information above and the instruction frequency distribution.

Thus, the average time per instruction with a variable clock is

$$\begin{aligned} \text{CPU clock cycle} &= 600 \times 25\% + 550 \times 10\% + 400 \times 45\% + 350 \times 15\% + 200 \times 5\% \\ &= 447.5 \text{ ps} \end{aligned}$$

Since the variable clock implementation has a shorter average clock cycle, it is clearly faster. Let's find the performance ratio:

$$\begin{aligned}
 \frac{\text{CPU performance}_{\text{variable clock}}}{\text{CPU performance}_{\text{single clock}}} &= \frac{\text{CPU execution time}_{\text{single clock}}}{\text{CPU execution time}_{\text{variable clock}}} \\
 &= \left(\frac{\text{IC} \times \text{CPU clock cycle}_{\text{single clock}}}{\text{IC} \times \text{CPU clock cycle}_{\text{variable clock}}} = \frac{\text{CPU clock cycle}_{\text{single clock}}}{\text{CPU clock cycle}_{\text{variable clock}}} \right) \\
 &= \frac{600}{447.5} = 1.34
 \end{aligned}$$

The variable clock implementation would be 1.34 times faster. Unfortunately, implementing a variable-speed clock for each instruction class is extremely difficult, and the overhead for such an approach could be larger than any advantage gained. As we will see in the next section, an alternative is to use a shorter clock cycle that does less work and then vary the number of clock cycles for the different instruction classes.

The penalty for using the single-cycle design with a fixed clock cycle is significant, but might be considered acceptable for this small instruction set. Historically, early machines with very simple instruction sets did use this implementation technique. However, if we tried to implement the floating-point unit or an instruction set with more complex instructions, this single-cycle design wouldn't work well at all. An example of this is shown in the  [For More Practice Exercise 5.4](#).

Because we must assume that the clock cycle is equal to the worst-case delay for all instructions, we can't use implementation techniques that reduce the delay of the common case but do not improve the worst-case cycle time. A single-cycle implementation thus violates our key design principle of making the common case fast. In addition, in this single-cycle implementation, each functional unit can be used only once per clock; therefore, some functional units must be duplicated, raising the cost of the implementation. A single-cycle design is inefficient both in its performance and in its hardware cost!

We can avoid these difficulties by using implementation techniques that have a shorter clock cycle—derived from the basic functional unit delays—and that require multiple clock cycles for each instruction. The next section explores this alternative implementation scheme. In Chapter 6, we'll look at another implementation technique, called pipelining, that uses a datapath very similar to the single-cycle datapath, but is much more efficient. Pipelining gains efficiency by overlapping the execution of multiple instructions, increasing hardware utilization and improving performance. For those readers interested primarily in the high-level concepts used in processors, the material of this section is sufficient to read the introductory sections of Chapter 6 and understand the basic functional-

ity of a pipelined processor. For those, who want to understand how the hardware really implements the control, forge ahead!

Check Yourself

Look at the control signal in Figure 5.22 on page 312. Can any control signal in the figure be replaced by the inverse of another? (Hint: Take into account the don't cares.) If so, can you use one signal for the other without adding an inverter?

5.5 A Multicycle Implementation

multicycle implementation Also called multiple clock cycle implementation. An implementation in which an instruction is executed in multiple clock cycles.

In an earlier example, we broke each instruction into a series of steps corresponding to the functional unit operations that were needed. We can use these steps to create a **multicycle implementation**. In a multicycle implementation, each *step* in the execution will take 1 clock cycle. The multicycle implementation allows a functional unit to be used more than once per instruction, as long as it is used on different clock cycles. This sharing can help reduce the amount of hardware required. The ability to allow instructions to take different numbers of clock cycles and the ability to share functional units within the execution of a single instruction are the major advantages of a multicycle design. Figure 5.25 shows the abstract version of the mul-

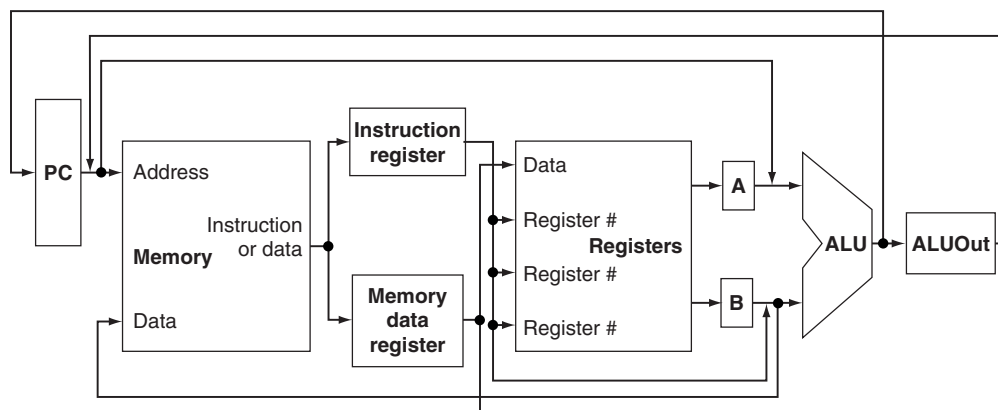

FIGURE 5.25 The high-level view of the multicycle datapath. This picture shows the key elements of the datapath: a shared memory unit, a single ALU shared among instructions, and the connections among these shared units. The use of shared functional units requires the addition or widening of multiplexors as well as new temporary registers that hold data between clock cycles of the same instruction. The additional registers are the Instruction register (IR), the Memory data register (MDR), A, B, and ALUOut.

ticycle datapath. If we compare Figure 5.25 to the datapath for the single-cycle version in Figure 5.11 on page 300, we can see the following differences:

- A single memory unit is used for both instructions and data.
- There is a single ALU, rather than an ALU and two adders.
- One or more registers are added after every major functional unit to hold the output of that unit until the value is used in a subsequent clock cycle.

At the end of a clock cycle, all data that is used in subsequent clock cycles must be stored in a state element. Data used by *subsequent instructions* in a later clock cycle is stored into one of the programmer-visible state elements: the register file, the PC, or the memory. In contrast, data used by the *same instruction* in a later cycle must be stored into one of these additional registers.

Thus, the position of the additional registers is determined by the two factors: what combinational units will fit in one clock cycle and what data are needed in later cycles implementing the instruction. In this multicycle design, we assume that the clock cycle can accommodate at most one of the following operations: a memory access, a register file access (two reads or one write), or an ALU operation. Hence, any data produced by one of these three functional units (the memory, the register file, or the ALU) must be saved, into a temporary register for use on a later cycle. If it were not saved then the possibility of a timing race could occur, leading to the use of an incorrect value.

The following temporary registers are added to meet these requirements:

- The Instruction register (IR) and the Memory data register (MDR) are added to save the output of the memory for an instruction read and a data read, respectively. Two separate registers are used, since, as will be clear shortly, both values are needed during the same clock cycle.
- The A and B registers are used to hold the register operand values read from the register file.
- The ALUOut register holds the output of the ALU.

All the registers except the IR hold data only between a pair of adjacent clock cycles and will thus not need a write control signal. The IR needs to hold the instruction until the end of execution of that instruction, and thus will require a write control signal. This distinction will become more clear when we show the individual clock cycles for each instruction.

Because several functional units are shared for different purposes, we need both to add multiplexors and to expand existing multiplexors. For example, since one memory is used for both instructions and data, we need a multiplexor to select between the two sources for a memory address, namely, the PC (for instruction access) and ALUOut (for data access).

Replacing the three ALUs of the single-cycle datapath by a single ALU means that the single ALU must accommodate all the inputs that used to go to the three different ALUs. Handling the additional inputs requires two changes to the datapath:

1. An additional multiplexor is added for the first ALU input. The multiplexor chooses between the A register and the PC.
2. The multiplexor on the second ALU input is changed from a two-way to a four-way multiplexor. The two additional inputs to the multiplexor are the constant 4 (used to increment the PC) and the sign-extended and shifted offset field (used in the branch address computation).

Figure 5.26 shows the details of the datapath with these additional multiplexors. By introducing a few registers and multiplexors, we are able to reduce the number of memory units from two to one and eliminate two adders. Since registers and multiplexors are fairly small compared to a memory unit or ALU, this could yield a substantial reduction in the hardware cost.

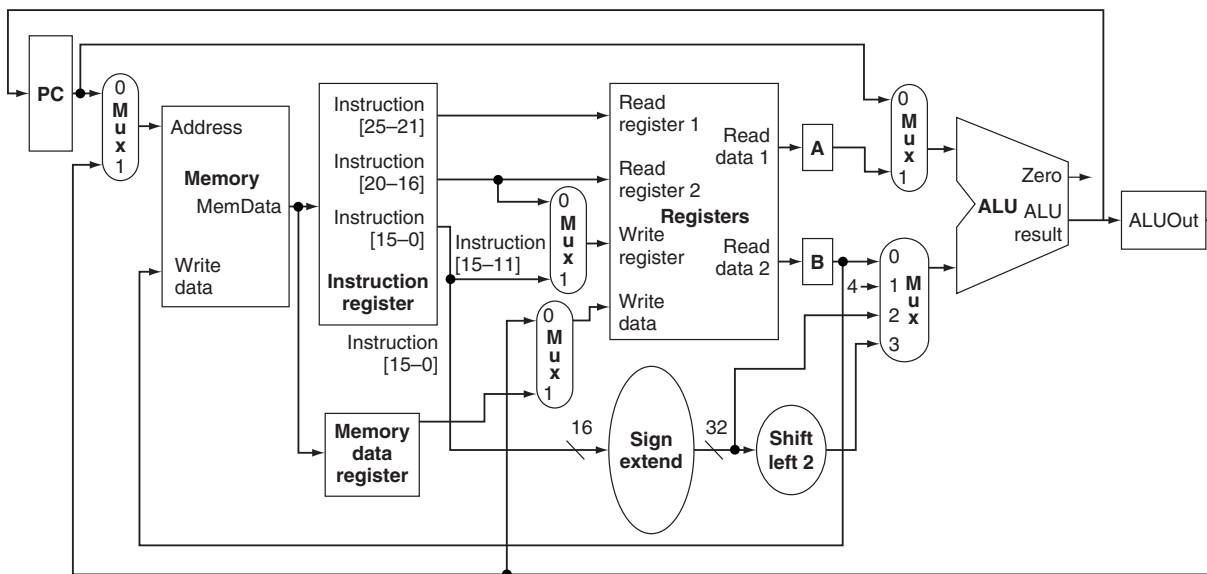

FIGURE 5.26 Multicycle datapath for MIPS handles the basic instructions. Although this datapath supports normal incrementing of the PC, a few more connections and a multiplexor will be needed for branches and jumps; we will add these shortly. The additions versus the single-clock datapath include several registers (IR, MDR, A, B, ALUOut), a multiplexor for the memory address, a multiplexor for the top ALU input, and expanding the multiplexor on the bottom ALU input into a four-way selector. These small additions allow us to remove two adders and a memory unit.

Because the datapath shown in Figure 5.26 takes multiple clock cycles per instruction, it will require a different set of control signals. The programmer-visible state units (the PC, the memory, and the registers) as well as the IR will need write control signals. The memory will also need a read signal. We can use the ALU control unit from the single-cycle datapath (see Figure 5.13 and [Appendix C](#)) to control the ALU here as well. Finally, each of the two-input multiplexors requires a single control line, while the four-input multiplexor requires two control lines. Figure 5.27 shows the datapath of Figure 5.26 with these control lines added.

The multicycle datapath still requires additions to support branches and jumps; after these additions, we will see how the instructions are sequenced and then generate the datapath control.

With the jump instruction and branch instruction, there are three possible sources for the value to be written into the PC:

1. The output of the ALU, which is the value $PC + 4$ during instruction fetch. This value should be stored directly into the PC.
2. The register ALUOut, which is where we will store the address of the branch target after it is computed.
3. The lower 26 bits of the Instruction register (IR) shifted left by two and concatenated with the upper 4 bits of the incremented PC, which is the source when the instruction is a jump.

As we observed when we implemented the single-cycle control, the PC is written both unconditionally and conditionally. During a normal increment and for jumps, the PC is written unconditionally. If the instruction is a conditional branch, the incremented PC is replaced with the value in ALUOut only if the two designated registers are equal. Hence, our implementation uses two separate control signals: PCWrite, which causes an unconditional write of the PC, and PCWriteCond, which causes a write of the PC if the branch condition is also true.

We need to connect these two control signals to the PC write control. Just as we did in the single-cycle datapath, we will use a few gates to derive the PC write control signal from PCWrite, PCWriteCond, and the Zero signal of the ALU, which is used to detect if the two register operands of a `beq` are equal. To determine whether the PC should be written during a conditional branch, we AND together the Zero signal of the ALU with the PCWriteCond. The output of this AND gate is then ORed with PCWrite, which is the unconditional PC write signal. The output of this OR gate is connected to the write control signal for the PC.

Figure 5.28 shows the complete multicycle datapath and control unit, including the additional control signals and multiplexor for implementing the PC updating.

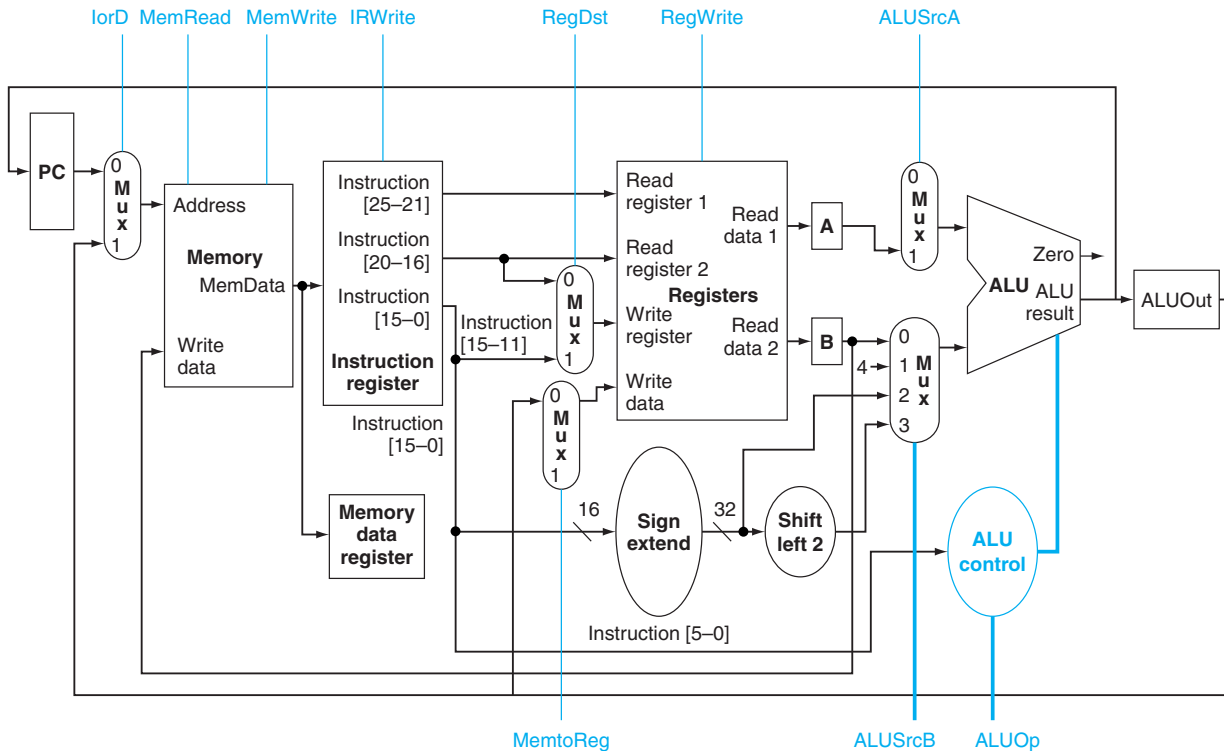

FIGURE 5.27 The multicycle datapath from Figure 5.26 with the control lines shown. The signals *ALUOp* and *ALUSrcB* are 2-bit control signals, while all the other control lines are 1-bit signals. Neither register A nor B requires a write signal, since their contents are only read on the cycle immediately after it is written. The memory data register has been added to hold the data from a load when the data returns from memory. Data from a load returning from memory cannot be written directly into the register file since the clock cycle cannot accommodate the time required for both the memory access and the register file write. The *MemRead* signal has been moved to the top of the memory unit to simplify the figures. The full set of datapaths and control lines for branches will be added shortly.

Before examining the steps to execute each instruction, let us informally examine the effect of all the control signals (just as we did for the single-cycle design in Figure 5.16 on page 306). Figure 5.29 shows what each control signal does when asserted and deasserted.

Elaboration: To reduce the number of signal lines interconnecting the functional units, designers can use *shared buses*. A shared bus is a set of lines that connect multiple units; in most cases, they include multiple sources that can place data on the bus

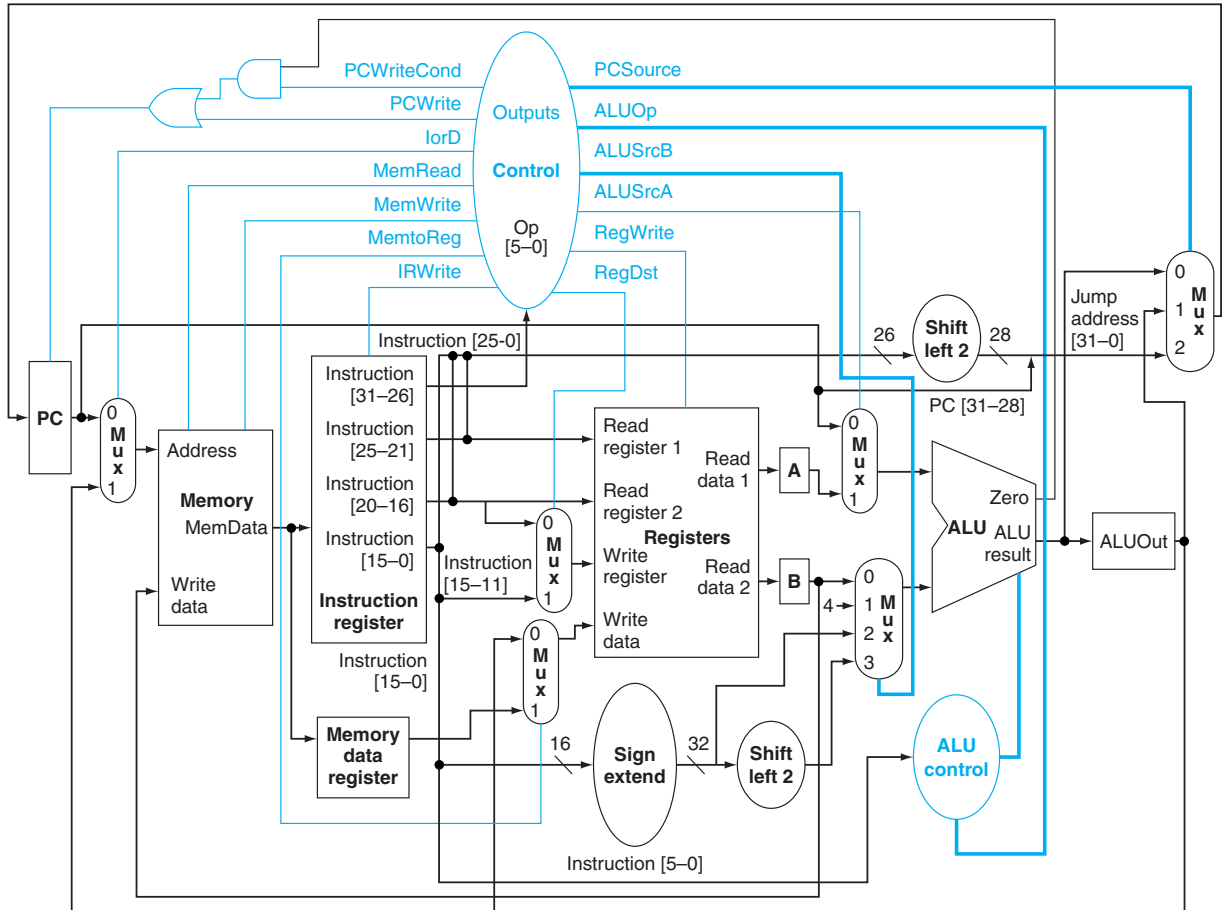

FIGURE 5.28 The complete datapath for the multicycle implementation together with the necessary control lines. The control lines of Figure 5.27 are attached to the control unit, and the control and datapath elements needed to effect changes to the PC are included. The major additions from Figure 5.27 include the multiplexer used to select the source of a new PC value; gates used to combine the PC write signals; and the control signals PCSource, PCWrite, and PCWriteCond. The PCWriteCond signal is used to decide whether a conditional branch should be taken. Support for jumps is included.

and multiple readers of the value. Just as we reduced the number of functional units for the datapath, we can reduce the number of buses interconnecting these units by sharing the buses. For example, there are six sources coming to the ALU; however, only two of them are needed at any one time. Thus, a pair of buses can be used to hold values that are being sent to the ALU. Rather than placing a large multiplexer in front of the

Actions of the 1-bit control signals

| Signal name | Effect when deasserted | Effect when asserted |
|-------------|--|---|
| RegDst | The register file destination number for the Write register comes from the rt field. | The register file destination number for the Write register comes from the rd field. |
| RegWrite | None. | The general-purpose register selected by the Write register number is written with the value of the Write data input. |
| ALUSrcA | The first ALU operand is the PC. | The first ALU operand comes from the A register. |
| MemRead | None. | Content of memory at the location specified by the Address input is put on Memory data output. |
| MemWrite | None. | Memory contents at the location specified by the Address input is replaced by value on Write data input. |
| MemtoReg | The value fed to the register file Write data input comes from ALUOut. | The value fed to the register file Write data input comes from the MDR. |
| lorD | The PC is used to supply the address to the memory unit. | ALUOut is used to supply the address to the memory unit. |
| IRWrite | None. | The output of the memory is written into the IR. |
| PCWrite | None. | The PC is written; the source is controlled by PCSrc. |
| PCWriteCond | None. | The PC is written if the Zero output from the ALU is also active. |

Actions of the 2-bit control signals

| Signal name | Value (binary) | Effect |
|-------------|----------------|---|
| ALUOp | 00 | The ALU performs an add operation. |
| | 01 | The ALU performs a subtract operation. |
| | 10 | The funct field of the instruction determines the ALU operation. |
| ALUSrcB | 00 | The second input to the ALU comes from the B register. |
| | 01 | The second input to the ALU is the constant 4. |
| | 10 | The second input to the ALU is the sign-extended, lower 16 bits of the IR. |
| | 11 | The second input to the ALU is the sign-extended, lower 16 bits of the IR shifted left 2 bits. |
| PCSrc | 00 | Output of the ALU ($PC + 4$) is sent to the PC for writing. |
| | 01 | The contents of ALUOut (the branch target address) are sent to the PC for writing. |
| | 10 | The jump target address ($IR[25:0]$ shifted left 2 bits and concatenated with $PC + 4[31:28]$) is sent to the PC for writing. |

FIGURE 5.29 The action caused by the setting of each control signal in Figure 5.28 on page 323. The top table describes the 1-bit control signals, while the bottom table describes the 2-bit signals. Only those control lines that affect multiplexors have an action when they are deasserted. This information is similar to that in Figure 5.16 on page 306 for the single-cycle datapath, but adds several new control lines (IRWrite, PCWrite, PCWriteCond, ALUSrcB, and PCSrc) and removes control lines that are no longer used or have been replaced (PCSrc, Branch, and Jump).

ALU, a designer can use a shared bus and then ensure that only one of the sources is driving the bus at any point. Although this saves signal lines, the same number of control lines will be needed to control what goes on the bus. The major drawback to using such bus structures is a potential performance penalty, since a bus is unlikely to be as fast as a point-to-point connection.

Breaking the Instruction Execution into Clock Cycles

Given the datapath in Figure 5.28, we now need to look at what should happen in each clock cycle of the multicycle execution, since this will determine what additional control signals may be needed, as well as the setting of the control signals. Our goal in breaking the execution into clock cycles should be to maximize performance. We can begin by breaking the execution of any instruction into a series of steps, each taking one clock cycle, attempting to keep the amount of work per cycle roughly equal. For example, we will restrict each step to contain at most one ALU operation, or one register file access, or one memory access. With this restriction, the clock cycle could be as short as the longest of these operations.

Recall that at the end of every clock cycle any data values that will be needed on a subsequent cycle must be stored into a register, which can be either one of the major state elements (e.g., the PC, the register file, or the memory), a temporary register written on every clock cycle (e.g., A, B, MDR, or ALUOut), or a temporary register with write control (e.g., IR). Also remember that because our design is edge-triggered, we can continue to read the current value of a register; the new value does not appear until the next clock cycle.

In the single-cycle datapath, each instruction uses a set of datapath elements to carry out its execution. Many of the datapath elements operate in series, using the output of another element as an input. Some datapath elements operate in parallel; for example, the PC is incremented and the instruction is read at the same time. A similar situation exists in the multicycle datapath. All the operations listed in one step occur in parallel within 1 clock cycle, while successive steps operate in series in different clock cycles. The limitation of one ALU operation, one memory access, and one register file access determines what can fit in one step.

Notice that we distinguish between reading from or writing into the PC or one of the stand-alone registers and reading from or writing into the register file. In the former case, the read or write is part of a clock cycle, while reading or writing a result into the register file takes an additional clock cycle. The reason for this distinction is that the register file has additional control and access overhead compared to the single stand-alone registers. Thus, keeping the clock cycle short motivates dedicating separate clock cycles for register file accesses.

The potential execution steps and their actions are given below. Each MIPS instruction needs from three to five of these steps:

1. Instruction fetch step

Fetch the instruction from memory and compute the address of the next sequential instruction:

```
IR <= Memory[PC];  
PC <= PC + 4;
```

Operation: Send the PC to the memory as the address, perform a read, and write the instruction into the Instruction register (IR), where it will be stored. Also, increment the PC by 4. We use the symbol “<=” from Verilog; it indicates that all right-hand sides are evaluated and then all assignments are made, which is effectively how the hardware executes during the clock cycle.

To implement this step, we will need to assert the control signals MemRead and IRWrite, and set IorD to 0 to select the PC as the source of the address. We also increment the PC by 4, which requires setting the ALUSrcA signal to 0 (sending the PC to the ALU), the ALUSrcB signal to 01 (sending 4 to the ALU), and ALUOp to 00 (to make the ALU add). Finally, we will also want to store the incremented instruction address back into the PC, which requires setting PC source to 00 and setting PCWrite. The increment of the PC and the instruction memory access can occur in parallel. The new value of the PC is not visible until the next clock cycle. (The incremented PC will also be stored into ALUOut, but this action is benign.)

2. Instruction decode and register fetch step

In the previous step and in this one, we do not yet know what the instruction is, so we can perform only actions that are either applicable to all instructions (such as fetching the instruction in step 1) or are not harmful, in case the instruction isn't what we think it might be. Thus, in this step we can read the two registers indicated by the rs and rt instruction fields, since it isn't harmful to read them even if it isn't necessary. The values read from the register file may be needed in later stages, so we read them from the register file and store the values into the temporary registers A and B.

We will also compute the branch target address with the ALU, which also is not harmful because we can ignore the value if the instruction turns out not to be a branch. The potential branch target is saved in ALUOut.

Performing these “optimistic” actions early has the benefit of decreasing the number of clock cycles needed to execute an instruction. We can do these optimistic actions early because of the regularity of the instruction formats. For instance, if the instruction has two register inputs, they are always in the rs and rt fields, and if the instruction is a branch, the offset is always the low-order 16 bits:

```
A <= Reg[IR[25:21]];
B <= Reg[IR[20:16]];
ALUOut <= PC + (sign-extend (IR[15:0]) << 2);
```

Operation: Access the register file to read registers rs and rt and store the results into the registers A and B. Since A and B are overwritten on every cycle, the register file can be read on every cycle with the values stored into A and B. This step also computes the branch target address and stores the address in ALUOut, where

it will be used on the next clock cycle if the instruction is a branch. This requires setting ALUSrcA to 0 (so that the PC is sent to the ALU), ALUSrcB to the value 11 (so that the sign-extended and shifted offset field is sent to the ALU), and ALUOp to 00 (so the ALU adds). The register file accesses and computation of branch target occur in parallel.

After this clock cycle, determining the action to take can depend on the instruction contents.

3. Execution, memory address computation, or branch completion

This is the first cycle during which the datapath operation is determined by the instruction class. In all cases, the ALU is operating on the operands prepared in the previous step, performing one of four functions, depending on the instruction class. We specify the action to be taken depending on the instruction class:

Memory reference:

```
ALUOut <= A + sign-extend (IR[15:0]);
```

Operation: The ALU is adding the operands to form the memory address. This requires setting ALUSrcA to 1 (so that the first ALU input is register A) and setting ALUSrcB to 10 (so that the output of the sign extension unit is used for the second ALU input). The ALUOp signals will need to be set to 00 (causing the ALU to add).

Arithmetic-logical instruction (R-type):

```
ALUOut <= A op B;
```

Operation: The ALU is performing the operation specified by the function code on the two values read from the register file in the previous cycle. This requires setting ALUSrcA = 1 and setting ALUSrcB = 00, which together cause the registers A and B to be used as the ALU inputs. The ALUOp signals will need to be set to 10 (so that the funct field is used to determine the ALU control signal settings).

Branch:

```
if (A == B) PC <= ALUOut;
```

Operation: The ALU is used to do the equal comparison between the two registers read in the previous step. The Zero signal out of the ALU is used to determine whether or not to branch. This requires setting ALUSrcA = 1 and setting ALUSrcB = 00 (so that the register file outputs are the ALU inputs). The ALUOp signals will need to be set to 01 (causing the ALU to subtract) for equality testing. The PCWriteCond signal will need to be asserted to update the PC if the Zero output of the ALU is asserted. By set-

ting PCSource to 01, the value written into the PC will come from ALUOut, which holds the branch target address computed in the previous cycle. For conditional branches that are taken, we actually write the PC twice: once from the output of the ALU (during the Instruction decode/register fetch) and once from ALUOut (during the Branch completion step). The value written into the PC last is the one used for the next instruction fetch.

Jump:

```
# {x, y} is the Verilog notation for concatenation of
bit fields x and y
PC <= {PC [31:28], (IR[25:0]], 2'b00)};
```

Operation: The PC is replaced by the jump address. PCSource is set to direct the jump address to the PC, and PCWrite is asserted to write the jump address into the PC.

4. Memory access or R-type instruction completion step

During this step, a load or store instruction accesses memory and an arithmetic-logical instruction writes its result. When a value is retrieved from memory, it is stored into the memory data register (MDR), where it must be used on the next clock cycle.

Memory reference:

```
MDR <= Memory [ALUOut];
```

or

```
Memory [ALUOut] <= B;
```

Operation: If the instruction is a load, a data word is retrieved from memory and is written into the MDR. If the instruction is a store, then the data is written into memory. In either case, the address used is the one computed during the previous step and stored in ALUOut. For a store, the source operand is saved in B. (B is actually read twice, once in step 2 and once in step 3. Luckily, the same value is read both times, since the register number—which is stored in IR and used to read from the register file—does not change.) The signal MemRead (for a load) or MemWrite (for store) will need to be asserted. In addition, for loads and stores, the signal IorD is set to 1 to force the memory address to come from the ALU, rather than the PC. Since MDR is written on every clock cycle, no explicit control signal need be asserted.

Arithmetic-logical instruction (R-type):

$$\text{Reg}[\text{IR}[15:11]] \leftarrow \text{ALUOut};$$

Operation: Place the contents of ALUOut, which corresponds to the output of the ALU operation in the previous cycle, into the Result register. The signal RegDst must be set to 1 to force the rd field (bits 15:11) to be used to select the register file entry to write. RegWrite must be asserted, and MemtoReg must be set to 0 so that the output of the ALU is written, as opposed to the memory data output.

5. Memory read completion step

During this step, loads complete by writing back the value from memory.

Load:

$$\text{Reg}[\text{IR}[20:16]] \leftarrow \text{MDR};$$

Operation: Write the load data, which was stored into MDR in the previous cycle, into the register file. To do this, we set MemtoReg = 1 (to write the result from memory), assert RegWrite (to cause a write), and we make RegDst = 0 to choose the rt (bits 20:16) field as the register number.

This five-step sequence is summarized in Figure 5.30. From this sequence we can determine what the control must do on each clock cycle.

| Step name | Action for R-type instructions | Action for memory-reference instructions | Action for branches | Action for jumps |
|--|-------------------------------------|--|---------------------------------------|---|
| Instruction fetch | | IR \leftarrow Memory[PC] PC \leftarrow PC + 4 | | |
| Instruction decode/register fetch | | A \leftarrow Reg [IR[25:21]] B \leftarrow Reg [IR[20:16]] ALUOut \leftarrow PC + (sign-extend (IR[15:0]) << 2) | | |
| Execution, address computation, branch/jump completion | ALUOut \leftarrow A op B | ALUOut \leftarrow A + sign-extend (IR[15:0]) | if (A == B) PC \leftarrow ALUOut | PC \leftarrow {PC [31:28], (IR[25:0]), 2'b00} |
| Memory access or R-type completion | Reg [IR[15:11]] \leftarrow ALUOut | Load: MDR \leftarrow Memory[ALUOut] or Store: Memory [ALUOut] \leftarrow B | | |
| Memory read completion | | Load: Reg[IR[20:16]] \leftarrow MDR | | |

FIGURE 5.30 Summary of the steps taken to execute any instruction class. Instructions take from three to five execution steps. The first two steps are independent of the instruction class. After these steps, an instruction takes from one to three more cycles to complete, depending on the instruction class. The empty entries for the Memory access step or the Memory read completion step indicate that the particular instruction class takes fewer cycles. In a multicycle implementation, a new instruction will be started as soon as the current instruction completes, so these cycles are not idle or wasted. As mentioned earlier, the register file actually reads every cycle, but as long as the IR does not change, the values read from the register file are identical. In particular, the value read into register B during the Instruction decode stage, for a branch or R-type instruction, is the same as the value stored into B during the Execution stage and then used in the Memory access stage for a store word instruction.

Defining the Control

Now that we have determined what the control signals are and when they must be asserted, we can implement the control unit. To design the control unit for the single-cycle datapath, we used a set of truth tables that specified the setting of the control signals based on the instruction class. For the multicycle datapath, the control is more complex because the instruction is executed in a series of steps. The control for the multicycle datapath must specify both the signals to be set in any step and the next step in the sequence.

In this subsection and in [Section 5.7](#), we will look at two different techniques to specify the control. The first technique is based on finite state machines that are usually represented graphically. The second technique, called **microprogramming**, uses a programming representation for control. Both of these techniques represent the control in a form that allows the detailed implementation—using gates, ROMs, or PLAs—to be synthesized by a CAD system. In this chapter, we will focus on the design of the control and its representation in these two forms.

[Section 5.8](#) shows how hardware design languages are used to design modern processors with examples of both the multicycle datapath and the finite state control. In modern digital systems design, the final step of taking a hardware description to actual gates is handled by logic and datapath synthesis tools. Appendix C shows how this process operates by translating the multicycle control unit to a detailed hardware implementation. The key ideas of control can be grasped from this chapter without examining the material in either [Section 5.8](#) or [Appendix C](#). However, if you want to actually do some hardware design, [Section 5.9](#) is useful, and [Appendix C](#) can show you what the implementations are likely to look like at the gate level.

Given this implementation, and the knowledge that each state requires 1 clock cycle, we can find the CPI for a typical instruction mix.

microprogram A symbolic representation of control in the form of instructions, called microinstructions, that are executed on a simple micromachine.

EXAMPLE

ANSWER

CPI in a Multicycle CPU

Using the SPECINT2000 instruction mix shown in Figure 3.26, what is the CPI, assuming that each state in the multicycle CPU requires 1 clock cycle?

The mix is 25% loads (1% load byte + 24% load word), 10% stores (1% store byte + 9% store word), 11% branches (6% beq, 5% bne), 2% jumps (1% jal + 1% jr), and 52% ALU (all the rest of the mix, which we assume to be ALU instructions). From Figure 5.30 on page 329, the number of clock cycles for each instruction class is the following:

- Loads: 5
- Stores: 4
- ALU instructions: 4
- Branches: 3
- Jumps: 3

The CPI is given by the following:

$$\begin{aligned} \text{CPI} &= \frac{\text{CPU clock cycles}}{\text{Instruction count}} = \frac{\sum \text{Instruction count}_i \times \text{CPI}_i}{\text{Instruction count}} \\ &= \sum \frac{\text{Instruction count}_i}{\text{Instruction count}} \times \text{CPI}_i \end{aligned}$$

The ratio

$$\frac{\text{Instruction count}_i}{\text{Instruction count}}$$

is simply the instruction frequency for the instruction class i . We can therefore substitute to obtain

$$\text{CPI} = 0.25 \times 5 + 0.10 \times 4 + 0.52 \times 4 + 0.11 \times 3 + 0.02 \times 3 = 4.12$$

This CPI is better than the worst-case CPI of 5.0 when all the instructions take the same number of clock cycles. Of course, overheads in both designs may reduce or increase this difference. The multicycle design is probably also more cost-effective, since it uses fewer separate components in the datapath.

The first method we use to specify the multicycle control is a **finite state machine**. A finite state machine consists of a set of states and directions on how to change states. The directions are defined by a **next-state function**, which maps the current state and the inputs to a new state. When we use a finite state machine for control, each state also specifies a set of outputs that are asserted when the machine is in that state. The implementation of a finite state machine usually assumes that all outputs that are not explicitly asserted are deasserted. Similarly, the correct operation of the datapath depends on the fact that a signal that is not explicitly asserted is deasserted, rather than acting as a don't care. For example, the RegWrite signal should be asserted only when a register file entry is to be written; when it is not explicitly asserted, it must be deasserted.

finite state machine A sequential logic function consisting of a set of inputs and outputs, a next-state function that maps the current state and the inputs to a new state, and an output function that maps the current state and possibly the inputs to a set of asserted outputs.

next-state function A combinational function that, given the inputs and the current state, determines the next state of a finite state machine.

Multiplexor controls are slightly different, since they select one of the inputs whether they are 0 or 1. Thus, in the finite state machine, we always specify the setting of all the multiplexor controls that we care about. When we implement the finite state machine with logic, setting a control to 0 may be the default and thus may not require any gates. A simple example of a finite state machine appears in Appendix B, and if you are unfamiliar with the concept of a finite state machine, you may want to examine [Appendix B](#) before proceeding.

The finite state control essentially corresponds to the five steps of execution shown on pages 325 through 329; each state in the finite state machine will take 1 clock cycle. The finite state machine will consist of several parts. Since the first two steps of execution are identical for every instruction, the initial two states of the finite state machine will be common for all instructions. Steps 3 through 5 differ, depending on the opcode. After the execution of the last step for a particular instruction class, the finite state machine will return to the initial state to begin fetching the next instruction.

Figure 5.31 shows this abstracted representation of the finite state machine. To fill in the details of the finite state machine, we will first expand the instruction fetch and decode portion, and then we will show the states (and actions) for the different instruction classes.

We show the first two states of the finite state machine in Figure 5.32 using a traditional graphic representation. We number the states to simplify the explanation, though the numbers are arbitrary. State 0, corresponding to step 1, is the starting state of the machine.

The signals that are asserted in each state are shown within the circle representing the state. The arcs between states define the next state and are labeled with

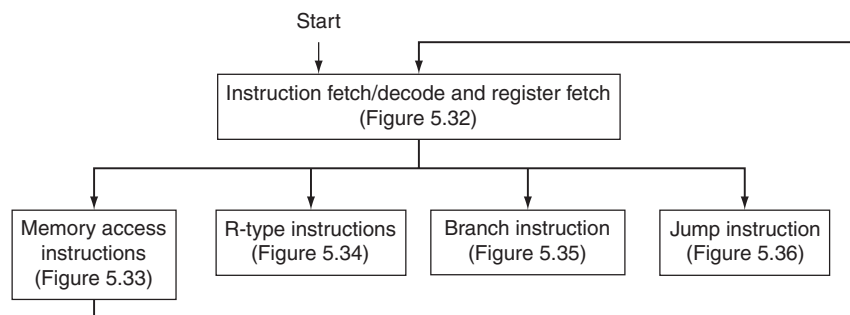

FIGURE 5.31 The high-level view of the finite state machine control. The first steps are independent of the instruction class; then a series of sequences that depend on the instruction opcode are used to complete each instruction class. After completing the actions needed for that instruction class, the control returns to fetch a new instruction. Each box in this figure may represent one to several states. The arc labeled *Start* marks the state in which to begin when the first instruction is to be fetched.

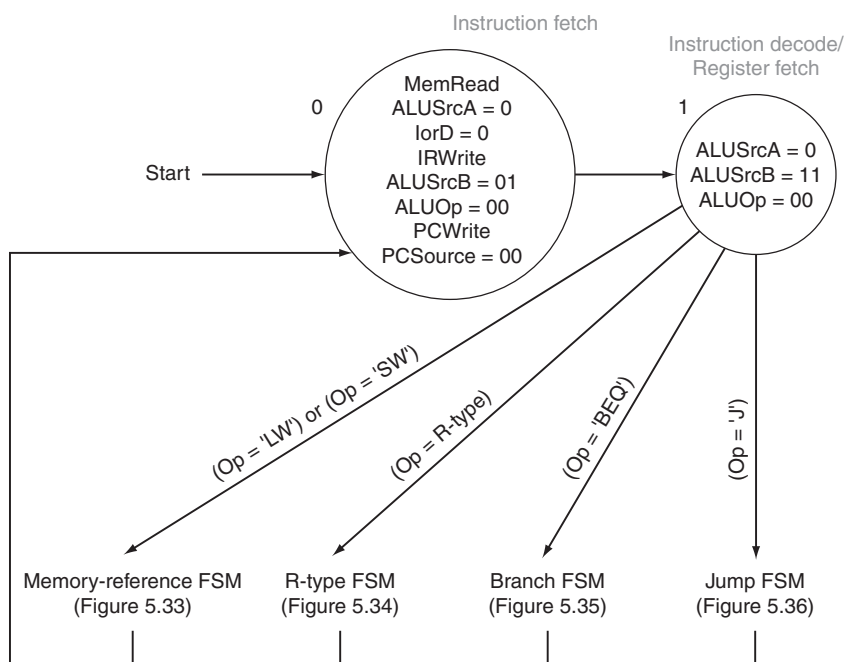

FIGURE 5.32 The instruction fetch and decode portion of every instruction is identical. These states correspond to the top box in the abstract finite state machine in Figure 5.31. In the first state we assert two signals to cause the memory to read an instruction and write it into the Instruction register (MemRead and IRWrite), and we set IorD to 0 to choose the PC as the address source. The signals ALUSrcA, ALUSrcB, ALUOp, PCWrite, and PCSource are set to compute $PC + 4$ and store it into the PC. (It will also be stored into ALUOut, but never used from there.) In the next state, we compute the branch target address by setting ALUSrcB to 11 (causing the shifted and sign-extended lower 16 bits of the IR to be sent to the ALU), setting ALUSrcA to 0 and ALUOp to 00; we store the result in the ALUOut register, which is written on every cycle. There are four next states that depend on the class of the instruction, which is known during this state. The control unit input, called Op, is used to determine which of these arcs to follow. Remember that all signals not explicitly asserted are deasserted; this is particularly important for signals that control writes. For multiplexors controls, lack of a specific setting indicates that we do not care about the setting of the multiplexor.

conditions that select a specific next state when multiple next states are possible. After state 1, the signals asserted depend on the class of instruction. Thus, the finite state machine has four arcs exiting state 1, corresponding to the four instruction classes: memory reference, R-type, branch on equal, and jump. This process of branching to different states depending on the instruction is called *decoding*, since the choice of the next state, and hence the actions that follow, depend on the instruction class.

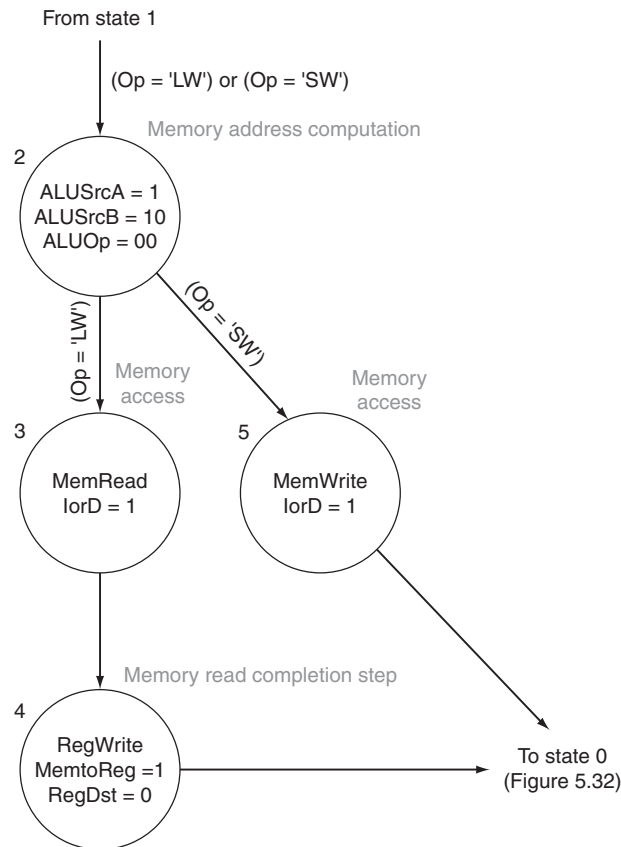

FIGURE 5.33 The finite state machine for controlling memory-reference instructions has four states. These states correspond to the box labeled “Memory access instructions” in Figure 5.31. After performing a memory address calculation, a separate sequence is needed for load and for store. The setting of the control signals ALUSrcA, ALUSrcB, and ALUOp is used to cause the memory address computation in state 2. Loads require an extra state to write the result from the MDR (where the result is written in state 3) into the register file.

Figure 5.33 shows the portion of the finite state machine needed to implement the memory-reference instructions. For the memory-reference instructions, the first state after fetching the instruction and registers computes the memory address (state 2). To compute the memory address, the ALU input multiplexers must be set so that the first input is the A register, while the second input is the sign-extended displacement field; the result is written into the ALUOut register. After the memory address calculation, the memory should be read or written; this requires two different states. If the instruction opcode is lw , then state 3 (corre-

sponding to the step Memory access) does the memory read (MemRead is asserted). The output of the memory is always written into MDR. If it is s_w , state 5 does a memory write (MemWrite is asserted). In states 3 and 5, the signal IorD is set to 1 to force the memory address to come from the ALU. After performing a write, the instruction s_w has completed execution, and the next state is state 0. If the instruction is a load, however, another state (state 4) is needed to write the result from the memory into the register file. Setting the multiplexor controls MemtoReg = 1 and RegDst = 0 will send the loaded value in the MDR to be written into the register file, using rt as the register number. After this state, corresponding to the Memory read completion step, the next state is state 0.

To implement the R-type instructions requires two states corresponding to steps 3 (Execute) and 4 (R-type completion). Figure 5.34 shows this two-state portion of the finite state machine. State 6 asserts ALUSrcA and sets the ALUSrcB

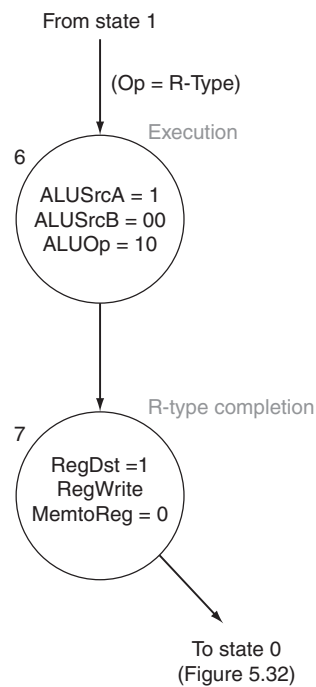

FIGURE 5.34 R-type instructions can be implemented with a simple two-state finite state machine. These states correspond to the box labeled “R-type instructions” in Figure 5.31. The first state causes the ALU operation to occur, while the second state causes the ALU result (which is in ALUOut) to be written in the register file. The three signals asserted during state 7 cause the contents of ALUOut to be written into the register file in the entry specified by the rd field of the Instruction register.

signals to 00; this forces the two registers that were read from the register file to be used as inputs to the ALU. Setting ALUOp to 10 causes the ALU control unit to use the function field to set the ALU control signals. In state 7, RegWrite is asserted to cause the register file to write, RegDst is asserted to cause the rd field to be used as the register number of the destination, and MemtoReg is deasserted to select ALUOut as the source of the value to write into the register file.

For branches, only a single additional state is necessary because they complete execution during the third step of instruction execution. During this state, the control signals that cause the ALU to compare the contents of registers A and B must be set, and the signals that cause the PC to be written conditionally with the address in the ALUOut register are also set. To perform the comparison requires that we assert ALUSrcA and set ALUSrcB to 00, and set the ALUOp value to 01 (forcing a subtract). (We use only the Zero output of the ALU, not the result of the subtraction.) To control the writing of the PC, we assert PCWriteCond and set PCSource = 01, which will cause the value in the ALUOut register (containing the branch address calculated in state 1, Figure 5.32 on page 333) to be written into the PC if the Zero bit out of the ALU is asserted. Figure 5.35 shows this single state.

The last instruction class is jump; like branch, it requires only a single state (shown in Figure 5.36) to complete its execution. In this state, the signal PCWrite is asserted to cause the PC to be written. By setting PCSource to 10, the value supplied for writing will be the lower 26 bits of the Instruction register with 00_{two} added as the low-order bits concatenated with the upper 4 bits of the PC.

We can now put these pieces of the finite state machine together to form a specification for the control unit, as shown in Figure 5.38. In each state, the signals that are asserted are shown. The next state depends on the opcode bits of the instruction, so we label the arcs with a comparison for the corresponding instruction opcodes.

A finite state machine can be implemented with a temporary register that holds the current state and a block of combinational logic that determines both the datapath signals to be asserted as well as the next state. Figure 5.37 shows how such an implementation might look. [Appendix C](#) describes in detail how the finite state machine is implemented using this structure. In [Section C.3](#), the combinational control logic for the finite state machine of Figure 5.38 is implemented both with a ROM (read-only memory) and a PLA (programmable logic array). (Also see [Appendix B](#) for a description of these logic elements.) In the next section of this chapter, we consider another way to represent control. Both of these techniques are simply different representations of the same control information.

Pipelining, which is the subject of Chapter 6, is almost always used to accelerate the execution of instructions. For simple instructions, pipelining is capable of achieving the higher clock rate of a multicycle design and a single-cycle CPI of a single-clock design. In most pipelined processors, however, some instructions take longer than a single cycle and require multicycle control. Floating point-

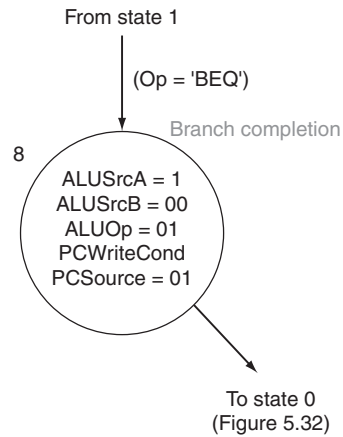

FIGURE 5.35 The branch instruction requires a single state. The first three outputs that are asserted cause the ALU to compare the registers (ALUSrcA, ALUSrcB, and ALUOp), while the signals PCSource and PCWriteCond perform the conditional write if the branch condition is true. Notice that we do not use the value written into ALUOut; instead, we use only the Zero output of the ALU. The branch target address is read from ALUOut, where it was saved at the end of state 1.

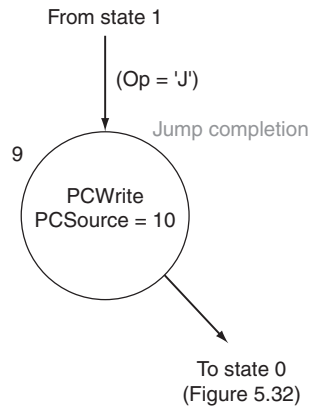

FIGURE 5.36 The jump instruction requires a single state that asserts two control signals to write the PC with the lower 26 bits of the Instruction register shifted left 2 bits and concatenated to the upper 4 bits of the PC of this instruction.

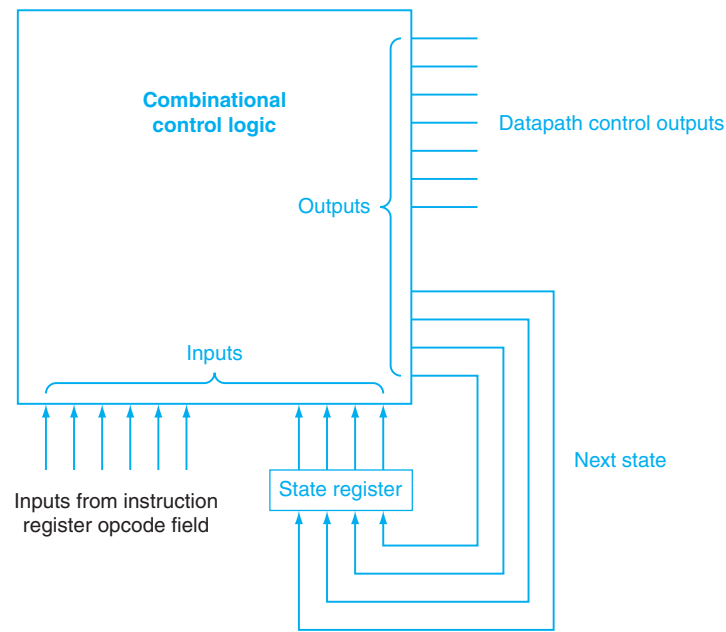

FIGURE 5.37 Finite state machine controllers are typically implemented using a block of combinational logic and a register to hold the current state. The outputs of the combinational logic are the next-state number and the control signals to be asserted for the current state. The inputs to the combinational logic are the current state and any inputs used to determine the next state. In this case, the inputs are the instruction register opcode bits. Notice that in the finite state machine used in this chapter, the outputs depend only on the current state, not on the inputs. The Elaboration above explains this in more detail.

instructions are one universal example. There are many examples in the IA-32 architecture that require the use of multicycle control.

Elaboration: The style of finite state machine in Figure 5.37 is called a Moore machine, after Edward Moore. Its identifying characteristic is that the output depends only on the current state. For a Moore machine, the box labeled combinational control logic can be split into two pieces. One piece has the control output and only the state input, while the other has only the next-state output.

An alternative style of machine is a Mealy machine, named after George Mealy. The Mealy machine allows both the input and the current state to be used to determine the output. Moore machines have potential implementation advantages in speed and size of the control unit. The speed advantages arise because the control outputs, which are needed early in the clock cycle, do not depend on the inputs, but only on the current state. In [Appendix C](#), when the implementation of this finite state machine is taken down to logic gates, the size advantage can be clearly seen. The potential disadvantage of a Moore machine is that it may require additional states. For example, in situations

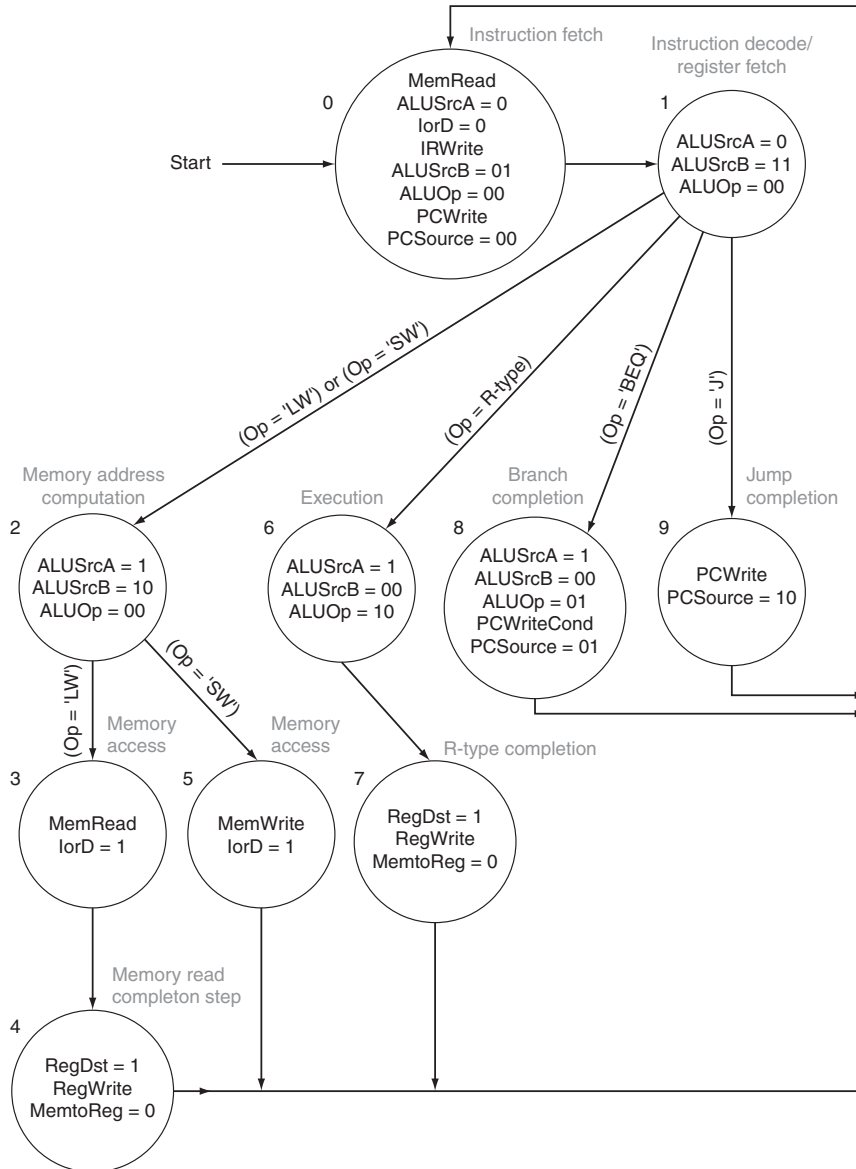

FIGURE 5.38 The complete finite state machine control for the datapath shown in Figure 5.28. The labels on the arcs are conditions that are tested to determine which state is the next state; when the next state is unconditional, no label is given. The labels inside the nodes indicate the output signals asserted during that state; we always specify the setting of a multiplexor control signal if the correct operation requires it. Hence, in some states a multiplexor control will be set to 0.

where there is a one-state difference between two sequences of states, the Mealy machine may unify the states by making the outputs depend on the inputs.

Understanding Program Performance

For a processor with a given clock rate, the relative performance between two code segments will be determined by the product of the CPI and the instruction count to execute each segment. As we have seen here, instructions can vary in their CPI, even for a simple processor. In the next two chapters, we will see that the introduction of pipelining and the use of caches create even larger opportunities for variation in the CPI. Although many factors that affect the CPI are controlled by the hardware designer, the programmer, the compiler, and software system dictate what instructions are executed, and it is this process that determines what the effective CPI for the program will be. Programmers seeking to improve performance must understand the role of CPI and the factors that affect it.

Check Yourself

1. True or false: Since the jump instruction does not depend on the register values or on computing the branch target address, it can be completed during the second state, rather than waiting until the third.
2. True, false, or maybe: The control signal `PCWriteCond` can be replaced by `PCSource[0]`.

5.6 Exceptions

exception Also called interrupt. An unscheduled event that disrupts program execution; used to detect overflow.

interrupt An exception that comes from outside of the processor. (Some architectures use the term *interrupt* for all exceptions.)

Control is the most challenging aspect of processor design: it is both the hardest part to get right and the hardest part to make fast. One of the hardest parts of control is implementing **exceptions** and **interrupts**—events other than branches or jumps that change the normal flow of instruction execution. An exception is an unexpected event from within the processor; arithmetic overflow is an example of an exception. An interrupt is an event that also causes an unexpected change in control flow but comes from outside of the processor. Interrupts are used by I/O devices to communicate with the processor, as we will see in Chapter 8.

Many architectures and authors do not distinguish between interrupts and exceptions, often using the older name *interrupt* to refer to both types of events. We follow the MIPS convention, using the term *exception* to refer to *any* unexpected change in control flow without distinguishing whether the cause is internal

or external; we use the term *interrupt* only when the event is externally caused. The Intel IA-32 architecture uses the word *interrupt* for all these events.

Interrupts were initially created to handle unexpected events like arithmetic overflow and to signal requests for service from I/O devices. The same basic mechanism was extended to handle internally generated exceptions as well. Here are some examples showing whether the situation is generated internally by the processor or externally generated:

| Type of event | From where? | MIPS terminology |
|---|-------------|------------------------|
| I/O device request | External | Interrupt |
| Invoke the operating system from user program | Internal | Exception |
| Arithmetic overflow | Internal | Exception |
| Using an undefined instruction | Internal | Exception |
| Hardware malfunctions | Either | Exception or interrupt |

Many of the requirements to support exceptions come from the specific situation that causes an exception to occur. Accordingly, we will return to this topic in Chapter 7, when we discuss memory hierarchies, and in Chapter 8, when we discuss I/O, and we better understand the motivation for additional capabilities in the exception mechanism. In this section, we deal with the control implementation for detecting two types of exceptions that arise from the portions of the instruction set and implementation that we have already discussed.

Detecting exceptional conditions and taking the appropriate action is often on the critical timing path of a machine, which determines the clock cycle time and thus performance. Without proper attention to exceptions during design of the control unit, attempts to add exceptions to a complicated implementation can significantly reduce performance, as well as complicate the task of getting the design correct.

How Exceptions Are Handled

The two types of exceptions that our current implementation can generate are execution of an undefined instruction and an arithmetic overflow. The basic action that the machine must perform when an exception occurs is to save the address of the offending instruction in the exception program counter (EPC) and then transfer control to the operating system at some specified address.

The operating system can then take the appropriate action, which may involve providing some service to the user program, taking some predefined action in response to an overflow, or stopping the execution of the program and reporting an error. After performing whatever action is required because of the exception, the operating system can terminate the program or may continue its execution, using the EPC to determine where to restart the execution

of the program. In Chapter 7, we will look more closely at the issue of restarting the execution.

For the operating system to handle the exception, it must know the reason for the exception, in addition to the instruction that caused it. There are two main methods used to communicate the reason for an exception. The method used in the MIPS architecture is to include a status register (called the *Cause register*), which holds a field that indicates the reason for the exception.

vectored interrupt An interrupt for which the address to which control is transferred is determined by the cause of the exception.

A second method is to use **vectored interrupts**. In a vectored interrupt, the address to which control is transferred is determined by the cause of the exception. For example, to accommodate the two exception types listed above, we might define the following two exception vector addresses:

| Exception type | Exception vector address (in hex) |
|-----------------------|-----------------------------------|
| Undefined instruction | C000 0000 _{hex} |
| Arithmetic overflow | C000 0020 _{hex} |

The operating system knows the reason for the exception by the address at which it is initiated. The addresses are separated by 32 bytes or 8 instructions, and the operating system must record the reason for the exception and may perform some limited processing in this sequence. When the exception is not vectored, a single entry point for all exceptions can be used, and the operating system decodes the status register to find the cause.

We can perform the processing required for exceptions by adding a few extra registers and control signals to our basic implementation and by slightly extending the finite state machine. Let's assume that we are implementing the exception system used in the MIPS architecture. (Implementing vectored exceptions is no more difficult.) We will need to add two additional registers to the datapath:

- *EPC*: A 32-bit register used to hold the address of the affected instruction. (Such a register is needed even when exceptions are vectored.)
- *Cause*: A register used to record the cause of the exception. In the MIPS architecture, this register is 32 bits, although some bits are currently unused. Assume that the low-order bit of this register encodes the two possible exception sources mentioned above: undefined instruction = 0 and arithmetic overflow = 1.

We will need to add two control signals to cause the *EPC* and *Cause* registers to be written; call these *EPCWrite* and *CauseWrite*. In addition, we will need a 1-bit control signal to set the low-order bit of the *Cause* register appropriately; call this signal *IntCause*. Finally, we will need to be able to write the *exception address*, which is the operating system entry point for exception handling, into the PC; in

the MIPS architecture, this address is $8000\ 0180_{\text{hex}}$. (The SPIM simulator for MIPS uses $8000\ 0080_{\text{hex}}$.) Currently, the PC is fed from the output of a three-way multiplexor, which is controlled by the signal `PCSource` (see Figure 5.28 on page 323). We can change this to a four-way multiplexor, with additional input wired to the constant value $8000\ 0180_{\text{hex}}$. Then `PCSource` can be set to 11_{two} to select this value to be written into the PC.

Because the PC is incremented during the first cycle of every instruction, we cannot just write the value of the PC into the EPC, since the value in the PC will be the instruction address plus 4. However, we can use the ALU to subtract 4 from the PC and write the output into the EPC. This requires no additional control signals or paths, since we can use the ALU to subtract, and the constant 4 is already a selectable ALU input. The data write port of the EPC, therefore, is connected to the ALU output. Figure 5.39 shows the multicycle datapath with these additions needed for implementing exceptions.

Using the datapath of Figure 5.39, the action to be taken for each different type of exception can be handled in one state apiece. In each case, the state sets the Cause register, computes and saves the original PC into the EPC, and writes the exception address into the PC. Thus, to handle the two exception types we are considering, we will need to add only the two states, but before we add them we must determine how to check for exceptions, since these checks will control the arcs to the new states.

How Control Checks for Exceptions

Now we have to design a method to detect these exceptions and to transfer control to the appropriate state in the exception states. Figure 5.40 shows the two new states (10 and 11) as well as their connection to the rest of the finite state control. Each of the two possible exceptions is detected differently:

- *Undefined instruction*: This is detected when no next state is defined from state 1 for the `op` value. We handle this exception by defining the next-state value for all `op` values other than `lw`, `sw`, `0` (R-type), `j`, and `beq` as state 10. We show this by symbolically using *other* to indicate that the `op` field does not match any of the opcodes that label arcs out of state 1 to the new state 10, which is used for this exception.
- *Arithmetic overflow*: The ALU, designed in [Appendix B](#), included logic to detect overflow, and a signal called *Overflow* is provided as an output from the ALU. This signal is used in the modified finite state machine to specify an additional possible next state (state 11) for state 7, as shown in Figure 5.40.

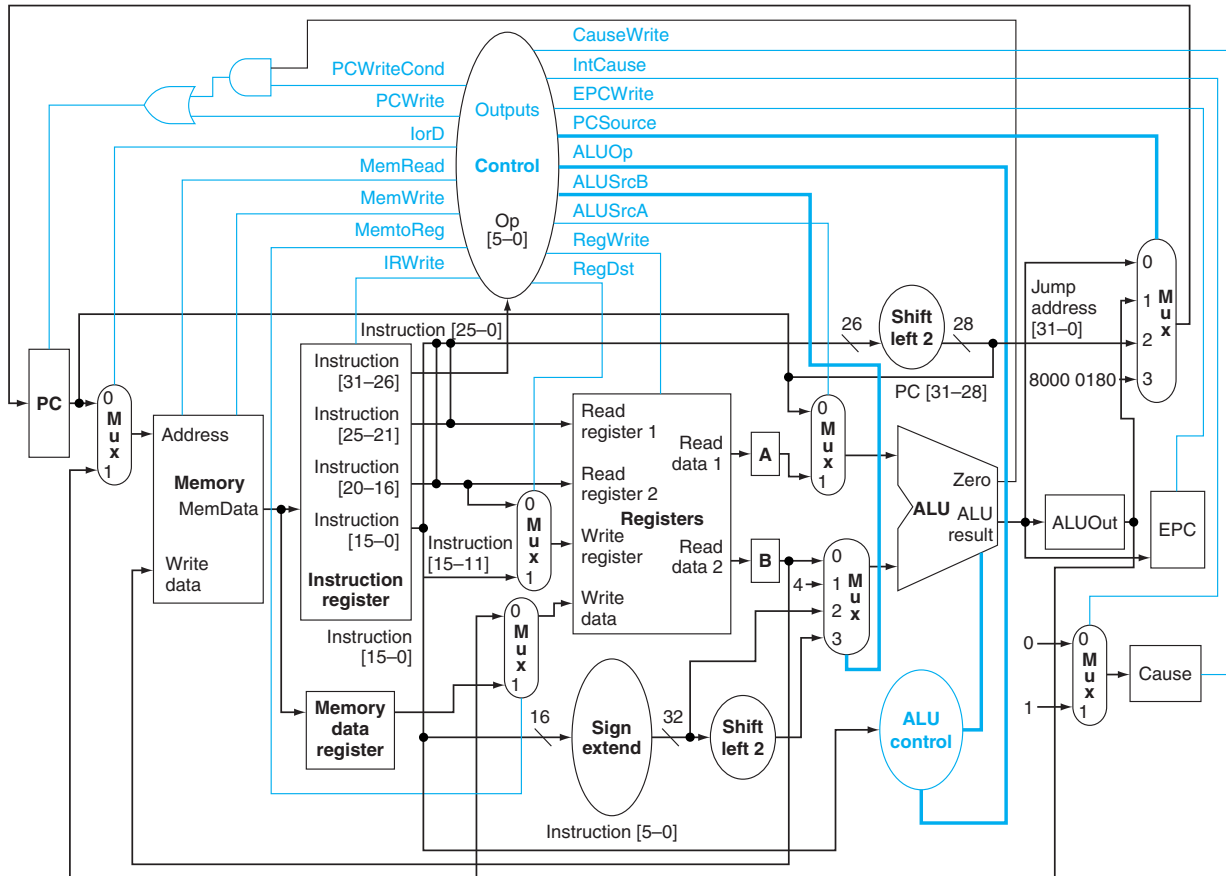

FIGURE 5.39 The multicycle datapath with the addition needed to implement exceptions. The specific additions include the Cause and EPC registers, a multiplexor to control the value sent to the Cause register, an expansion of the multiplexor controlling the value written into the PC, and control lines for the added multiplexor and registers. For simplicity, this figure does not show the ALU overflow signal, which would need to be stored in a one-bit register and delivered as an additional input to the control unit (see Figure 5.40 to see how it is used).

Figure 5.40 represents a complete specification of the control for this MIPS subset with two types of exceptions. Remember that the challenge in designing the control of a real machine is to handle the variety of different interactions between instructions and other exception-causing events in such a way that the control logic remains both small and fast. The complex interactions that are possible are what make the control unit the most challenging aspect of hardware design.

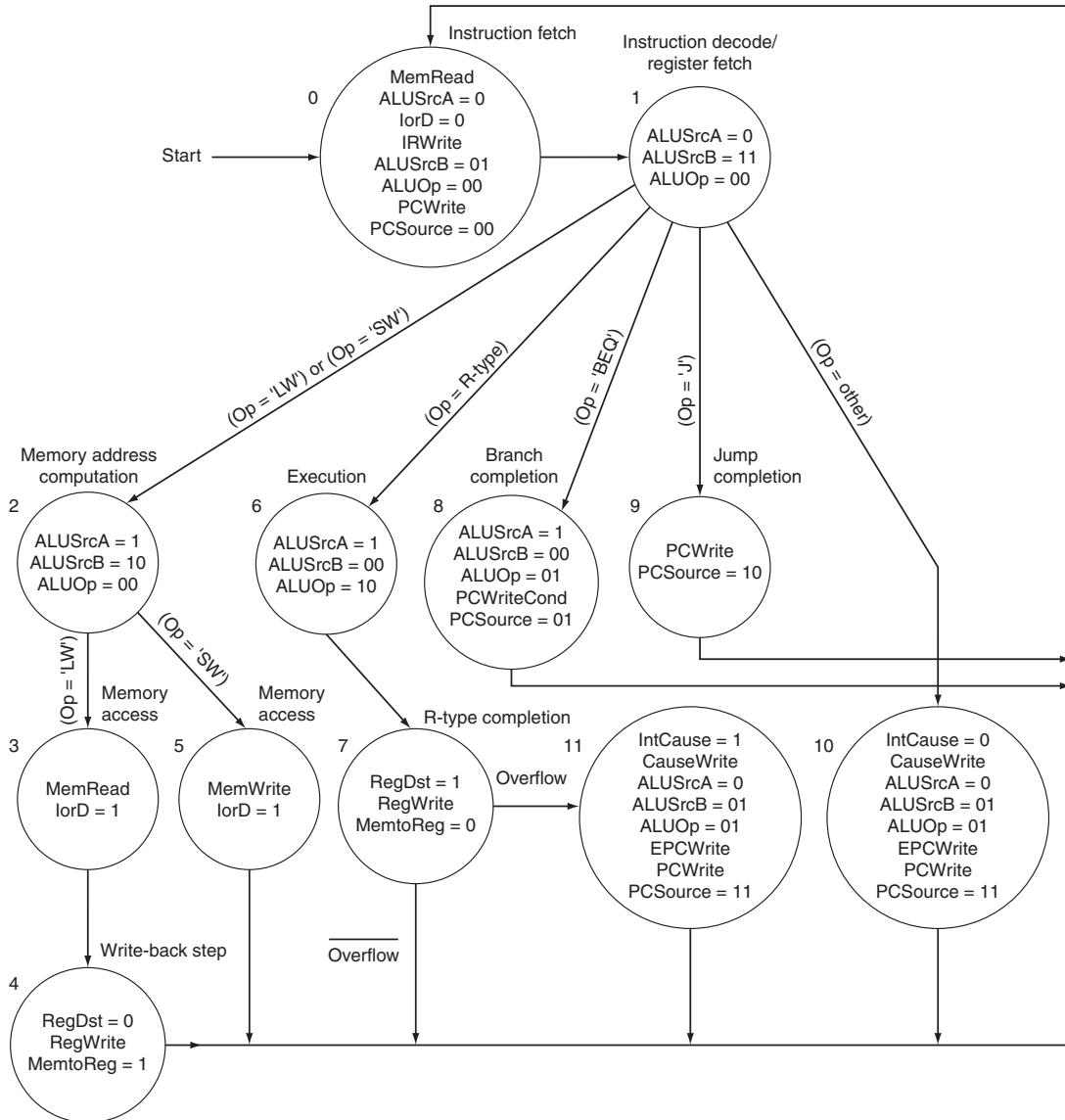

FIGURE 5.40 This shows the finite state machine with the additions to handle exception detection. States 10 and 11 are the new states that generate the appropriate control for exceptions. The branch out of state 1 labeled *(Op = other)* indicates the next state when the input does not match the opcode of any of lw, sw, 0 (R-type), j, or beq. The branch out of state 7 labeled *Overflow* indicates the action to be taken when the ALU signals an overflow.

Elaboration: If you examine the finite state machine in Figure 5.40 closely, you can see that some problems could occur in the way the exceptions are handled. For example, in the case of arithmetic overflow, the instruction causing the overflow completes writing its result because the overflow branch is in the state when the write completes. However, it's possible that the architecture defines the instruction as having no effect if the instruction causes an exception; this is what the MIPS instruction set architecture specifies. In Chapter 7, we will see that certain classes of exceptions require us to prevent the instruction from changing the machine state, and that this aspect of handling exceptions becomes complex and potentially limits performance.

Check Yourself

Is this optimization proposed in the Check Yourself on page 340 concerning PCSource still valid in the extended control for exceptions shown in Figure 5.40 on page 345? Why or why not?



5.7 Microprogramming: Simplifying Control Design

Microprogramming is a technique for designing complex control units. It uses a very simple hardware engine that can then be programmed to implement a more complex instruction set. Microprogramming is used today to implement some parts of a complex instruction set, such as a Pentium, as well as in special-purpose processors. This section, which appears on the CD, explains the basic concepts and shows how they can be used to implement the MIPS multicycle control.



5.8 An Introduction to Digital Design Using a Hardware Design Language

Modern digital design is done using hardware description languages and modern computer-aided synthesis tools that can create detailed hardware designs from the descriptions using both libraries and logic synthesis. Entire books are written on such languages and their use in digital design. This section, which appears on the CD, gives a brief introduction and shows how a hardware design language, Verilog in this case, can be used to describe the MIPS multicycle control both behaviorally and in a form suitable for hardware synthesis.