

Equipment Required

- P2116/2(329) Fast-Plastic Scintillator/Photomultiplier Assembly. ½-inch diameter x 4-inches long (1.27 x 10.2-cm).
- 905-3 2-inch x 2-inch (5.08-cm x 5.08-cm) NaI(Tl) Detector/Photomultiplier Assembly.
- Two 113 Preamplifiers.
- Two 556 High Voltage Power Supplies.
- 266 Photomultiplier Tube Base.
- 265A Photomultiplier Tube Base.
- 480 Pulser.
- 855 Dual Spectroscopy Amplifier.
- 427A Delay Amplifier.
- 551 Timing Single-Channel Analyzer.
- 416A Gate and Delay Generator.
- 4001A/4002D NIM Bin and Power Supply.
- EASY-MCA-2K System including USB cable and MAESTRO-32 software (other ORTEC MCAs may be substituted).
- PC-1 Personal Computer with a USB port and a recent, supportable version of the Windows operating system.
- TDS3032C Oscilloscope with bandwidth ≥ 150 MHz.
- Cables and Connectors:
 - Two C-36-12 RG-59A/U Coaxial Cables with SHV Female Plugs, 12-ft. (3.7-m) length.
 - Five C-24-1 RG-62A/U Coaxial Cables with BNC Plugs, 1-ft. (30-cm) length.
 - Three C-24-4 RG-62A/U 93- Ω Coaxial Cables with BNC Plugs, 4-ft. (1.2-m) length.
 - Four C-24-12 RG-62A/U Coaxial Cables with BNC Plugs, 12-ft. (3.7-m) length.
 - One C-29 BNC Tee Connector.
- 306-AX Angular Correlation Table (with two detector shields, two rotating detector arms, and one shielded source collimator/enclosure).
- AL-ROD-AX Aluminum Scattering Rod, 0.5-in diameter x 4-in. long (1.27 cm x 10.2 cm), ASTM 6061-T651 alloy.
- CS173-5M 5-mCi ¹³⁷Cs Source. A license is required for this source.
- RSS8 Gamma-Ray Source Kit including: ¹³⁹Ba, ¹⁰⁹Cd, ⁵⁷Co, ⁶⁰Co, ¹³⁷Cs, ⁵⁴Mn and ²²Na, each with a 1 μ Ci source activity, and a Cs/Zn mixed source incorporating 0.5 μ Ci of ¹³⁷Cs and 1 μ Ci of ⁶⁵Zn. The source kit enables energy calibration from 32 to 1333 keV.

Purpose

This experiment explores Compton Scattering using the 662-keV gamma-ray from a 5 mCi ¹³⁷Cs radioactive source. The dependence of the scattered gamma-ray energy on the scattering angle will be measured and compared to the theoretical equation. Additionally, the differential scattering cross section will be measured and compared to the theoretical Klein-Nishina expression. Initial measurements will use an aluminum rod as the scatterer. Subsequently, the aluminum rod will be replaced with a plastic scintillator. This substitution allows coincidence techniques to be employed to reduce the interfering background, and permits measurement of the electron recoil energy.

Relevant Information

The collision of a gamma ray with a free electron is explained by the Compton-scattering theory. The kinematic equations describing this interaction are exactly the same as the equations for two billiard balls colliding with each other, except that the balls are of two different sizes. Fig. 10.1 shows the interaction.

Experiment 10 Compton Scattering

In Fig. 10.1 a gamma of energy E_γ scatters from a free electron. After scattering, the gamma-ray departs at an angle θ with respect to its original direction. The energy of the scattered gamma-ray is lowered to $E_{\gamma'}$. That difference in gamma-ray energies is transferred to the electron, which recoils at an angle ϕ with respect to the original gamma-ray direction, and carries off an energy E_e . The laws of conservation of energy and momentum for the interaction are as follows:

Conservation of energy:

$$E_\gamma = E_{\gamma'} + E_e \quad (1)$$

Conservation of momentum:

X direction:

$$\frac{h\nu}{c} = \frac{h\nu'}{c} \cos\theta + m v_e \cos\phi \quad (2a)$$

Y direction:

$$0 = \frac{h\nu'}{c} \sin\theta - m v_e \sin\phi \quad (2b)$$

In equations (1), (2) and (3), ν and ν' are the frequencies of the incident and scattered gamma rays, respectively, and h is Planck's Constant (6.63×10^{-27} erg sec.). Consequently,

$$E_\gamma = h\nu \quad (3a)$$

$$E_{\gamma'} = h\nu' \quad (3b)$$

Also

$$E_e = mc^2 - m_0c^2 \quad (3c)$$

$$m = \frac{m_0}{\sqrt{1 - \frac{v_e^2}{c^2}}} \quad (3d)$$

For the electron, the rest mass is m_0 , and the recoil velocity is v_e .

Solving equations (1), (2) and (3) results in the well-known equation expressing the energy of the Compton-scattered gamma ray as a function of the scattering angle, θ .

$$E_{\gamma'} = \frac{E_\gamma}{1 + \frac{E_\gamma}{m_0c^2} (1 - \cos\theta)} \quad (4)$$

Note that Eq. (4) is easy to use if all energies are expressed in MeV. From Experiments 3 and 7, the rest-mass equivalent energy of the electron, m_0c^2 , is equal to 0.511 MeV. In this experiment, E_γ is the energy of the source (0.662 MeV for ^{137}Cs), and θ is the measured laboratory scattering angle.

Equation (4) is convenient for calculating the energy of the Compton-scattered gamma ray if the original energy and scattering angle are known. For comparing the predicted $E_{\gamma'}$ to the measured $E_{\gamma'}$ in this experiment, it is useful to rearrange equation (4) to the form:

$$\frac{1}{E_{\gamma'}} = \frac{1}{E_\gamma} + \left[\frac{1}{m_0c^2} \right] (1 - \cos\theta) \quad (5a)$$

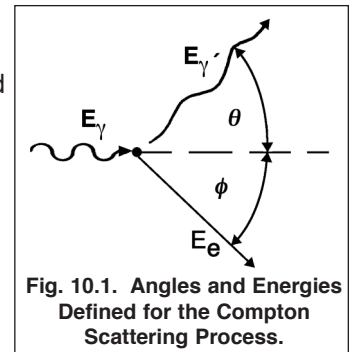

Fig. 10.1. Angles and Energies Defined for the Compton Scattering Process.

For $E_\gamma = 0.662$ MeV and $m_0c^2 = 0.511$ MeV, equation (5a) becomes

$$\frac{1}{E_{\gamma'}} = 1.51 + 1.957 (1 - \cos\theta) \quad (5b)$$

Hence, if $(1/E_{\gamma'})$ is plotted against $(1 - \cos\theta)$ on a linear graph equation (5b) will form a straight line with a slope of 1.957 MeV^{-1} and an intercept of 1.51 MeV^{-1} .

Calculating the Peak Position Uncertainty

If the background under the photopeak is negligible, as it should be in this experiment, and the position of the photopeak is calculated as the centroid of the area under the peak, counting statistics will contribute a predicted standard deviation in the centroid energy given by

$$\sigma_{E_{\gamma'}} = \frac{\text{FWHM}}{2.35 \sqrt{\Sigma_{\gamma'}}} \quad (6)$$

Where FWHM is the full width of the photopeak in MeV at half the height of the peak, and $\Sigma_{\gamma'}$ is the total counts in the region of interest set across the entire width of the peak at the baseline (ref. 9). Equation (6) can be used to estimate the measurement error in the photopeak position for plotting on the graphs below.

Apparatus and Geometry

Fig. 10.2 shows the geometry used for the experiments described below for Compton scattering. Experiments 10.1 and 10.2 are simple scattering experiments using an aluminum scattering sample. In Experiments 10.3 and 10.4 the aluminum sample is replaced with an organic scintillator coupled to a phototube, and a coincidence is required between the pulse in the organic scintillator and a pulse in the NaI(Tl) crystal. This coincidence scheme lowers the interfering background in the spectra and permits the electron recoil energy to be measured.

The Compton scattering experiments are set up by employing the 306-AX Angular Correlation Table. As indicated in Figure 10.2, the source to scatterer distance, $R_1 = 12$ inches (30.5 cm), and the distance from the center of the scatterer to the front surface of the NaI(Tl) detector is $R_2 = 12$ inches (30.5 cm). The shielded source container incorporates a square collimator on its front surface that limits the area illuminated by the gamma rays at the center of the scatterer to a 2-inch wide by 2-inch tall square (5.08 cm x 5.08 cm). As instructed in the appendix, this illuminated square should be centered on the scatterer. Thus the illuminated volume of the scatterer will be confined to 5.08 cm along its axial length and the 1.27 cm width determined by the 0.5-inch diameter of the rod or scintillator.

The 5 mCi ^{137}Cs source should already be installed in its shielded collimator by the Laboratory Manager, and the NaI(Tl) detector with its lead shield should already be mounted on the arm that provides for setting the desired scattering angle. See the appendix on this experiment for details on setting up and aligning the apparatus.

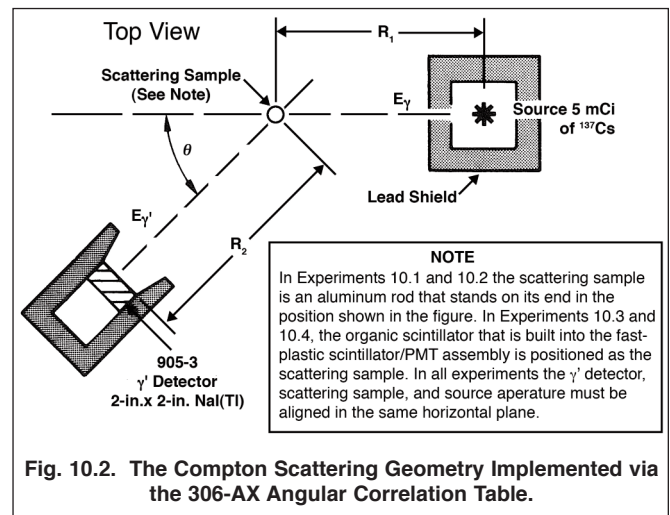

Experiment 10

Compton Scattering

CAUTION

The ^{137}Cs source employed in this experiment has a very high activity (5 mCi). To reduce radiation exposure, handling of the small 6.4 mm diameter source capsule should be minimized, and tongs should be employed to increase the distance from the source capsule to the hands. Once the source is properly installed in the shielded collimator and the cover is secured over the collimator opening, the radiation exposure is reduced to less than that caused by a $1\ \mu\text{Ci}$ source at a minimum distance of 7.6 cm. This shielding can be used for storing the source when not being used in the measurement.

During the Compton scattering experiment, the cover over the collimator opening must be removed. While the cover is open, minimize the time any body parts are inserted into the direct beam of gamma rays streaming through the collimator, and maximize your distance from the source in that direct beam.

For safety, the shielded cover should be applied over the collimator opening whenever the output from the source is not needed. If the enclosed source is left unattended, that collimator cover should be secured with a lock to dissuade tampering.

EXPERIMENT 10.1. Simple Compton Scattering: Energy Determination

Procedure

- Using $E_\gamma = 0.662\ \text{MeV}$ for ^{137}Cs in Eq. (4), calculate the values for $E_{\gamma'}$ and enter them in Table 10.1 for the angles listed.
- Set up the electronics as shown in Fig. 10.3. More specifically:
- Check that the NaI(Tl) detector and PMT assembly is properly inserted in the lead shield on the movable arm. The annular shield should protrude 2 inches (5.08 cm) beyond the front surface of the detector, and the distance from the front surface of the NaI(Tl) crystal to the center of the aluminum rod should be 12 inches (30.5 cm).
- Verify that the 5 mCi ^{137}Cs source in its shield is properly mounted with the source positioned 12 inches (30.5 cm) from the center of the aluminum scatterer. The location of the source in the shield is marked on the outside of the shield (10.2 cm behind the front, outside surface of the collimator).

Table 10.1. Data for the Aluminum Scatterer.

θ (degrees)	Calculated $E_{\gamma'}$ (MeV)	Measured $E_{\gamma'}$ (MeV)	Preset Live Time, t_L (seconds)	Photopeak Sum, $\Sigma_{\gamma'}$	Photopeak FWHM (MeV)
0					
20					
40					
60					
80					
100					
120					
140					
160					
180					

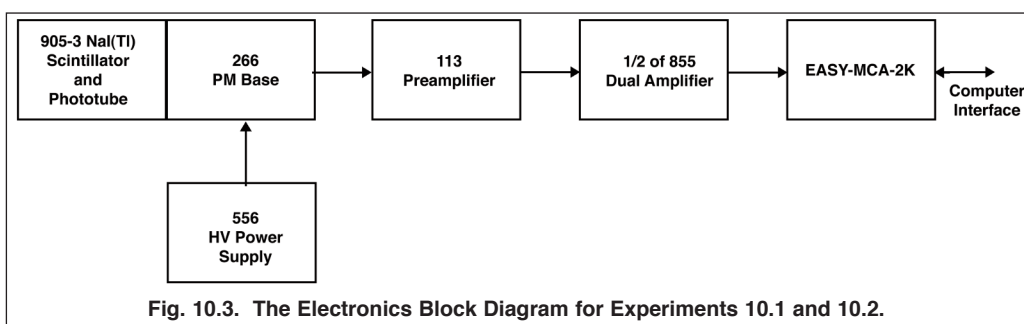

Ensure that the cover shield is in place over the source collimator to shut off the output of 662 keV gamma rays.

- Turn off the power to the NIM Bin and install the modules in the bin.
- Turn off the power switch on the 556 HV Power Supply. Confirm that the POLARITY switch on the rear panel is in the POSitive position. Check that the CONTROL switch is set to INTernal. Using a RG-59A/U coaxial cable with SHV plugs, connect one of the high voltage OUTPUTS on the rear of the 556 to the POSitive HV input on the 266 PMT Base. Set the voltage controls on the front panel of the 556 to the value recommended by the manufacturer of the NaI(Tl) detector.

Experiment 10 Compton Scattering

7. Connect the ANODE output of the 266 PMT Base to the INPUT of the 113 Preamplifier using the shortest RG-62A/U 93-Ω coaxial cable. Set the INPUT CAPacitance of the 113 to 100 pF.
8. On the 855 Dual Amplifier, verify that the printed-circuit-board-mounted jumpers are set for a NEGative input polarity for both halves of the module. Set the SHAPING TIME switches to 0.5 μs for both halves of the module.
9. Connect the POWER cable from the 113 Preamplifier to one of the PREAMP POWER plugs on the rear panel of the 855. Using a 12-ft. (3.7-m) RG-62A/U 93-Ω coaxial cable, connect the 113 OUTPUT to one of the INputs on the 855 Dual Amplifier.
10. With a 93 Ω RG-62A/U coaxial cable connect the UNipolar output of the selected half of the 855 to the analog INPUT of the EASY-MCA-2K.
11. Check that the EASY-MCA-2K is connected to the supporting computer via a USB cable, and that MAESTRO-32 software is operating on the computer. Set the MCA gating condition to OFF. Select a conversion gain of 512 channels, and set the upper level discriminator to 512 channels. Select a value of 10 channels for the lower level discriminator.
12. Turn on the 4001A/4002D NIM Bin power, and turn on the 556 HV Power Supply.
13. From the RSS8 source kit select the 1 μCi ¹³⁷Cs source and place it directly in front of the NaI(Tl) detector. Adjust the amplifier gain so that the 662 keV peak is located at circa channel 400 during acquisition by the MCA. Lock the FINE GAIN dial to discourage accidental changes.
14. Employing the procedure taught in Experiment 3, adjust the Pole-Zero (P/Z) cancellation on the 855 Amplifier to make the output pulses return to baseline as quickly as possible without undershooting.
15. Remove the 1 μCi ¹³⁷Cs source and acquire a spectrum. Ensure that the MCA is not acquiring significant noise events near channel 10. If the noise is accumulating at a noticeable counting rate and the MCA dead time is >1%, raise the lower level discriminator setting until the noise is no longer observed.
16. Select the appropriate sources from the RSS8 source kit and calibrate the EASY-MCA-2K so that its cursor reads the correct energy of the photopeaks. Table 10.2 lists the gamma-ray energies for the isotopes in the source kit.
17. Remove the energy-calibration sources. Install the aluminum rod vertically in the scattering position at the center of the table. Next, remove the cover shield from the collimator on the 5 mCi ¹³⁷Cs source enclosure.
18. Position the NaI(Tl) detector at θ = 60°. This is the position at which the lowest counting rate will be recorded. Set the preset live time on the EASY-MCA-2K at 100 seconds, and acquire a spectrum for that live time.
19. Set a Region of Interest (ROI) across the entire photopeak from the valley on the lower energy side to the baseline on the higher energy side. Sum the counts in the photopeak using the ROI integration feature of the MAESTRO-32 software. Read the “Net Area” which

Isotope	Half Life	X-ray Series	X-ray Energies (keV)	Gamma-Ray Energies (keV)
²² Na	950.8d			511
				1275
⁵⁴ Mn	312.3d	Cr K	5.414	835
			5.405	
			5.946	
⁵⁷ Co	271.79 d	Fe K	6.403	14
			6.390	122
			7.057	136.5
⁶⁰ Co	5.272 y			1173
				1333
⁶⁵ Zn	244.26 d	Cu K	8.047	1116
			8.027	
			8.904	
			8.976	
¹⁰⁹ Cd	462.6 d	Ag K	22.162	88
			21.988	
			24.942	
			25.454	
¹³³ Ba	3862 d	Cs K	30.970	80
			30.623	303
			34.984	356
			35.819	
¹³⁷ Cs	30.17 y	Ba K	32.191	662
			31.815	
			36.376	
			37.255	

Experiment 10 Compton Scattering

reports the area above any background under the peak. The background should be negligible.

20. From the result in step 19, determine the preset live time necessary to accumulate at least 1,000 net counts in the photopeak. Use this preset live time for acquiring the spectra at each of the angles in Table 10.1. Note that the spectrum will not be measured at 0° because of an excessive counting rate from the unscattered radiation from the source. No measurement will be made at 180° because the lead shields make that angle inaccessible.
21. For each of the angles in Table 10.1 (except 0° and 180°), acquire a spectrum for the preset live time determined in step 20. In each case, set an ROI across the photopeak as described in step 19. Using the MAESTRO-32 features, measure the peak position (centroid) and the net area of the peak. Record those numbers in the 3rd and 5th columns of Table 10.1. Measure the FWHM of each photopeak and record that value in Table 10.1. You may wish to save a copy of each spectrum on the hard disk, in case you find a reason later to re-examine the raw data. As predicted by equation (4), the photopeak energy will decrease as θ increases. Figure 10.4 shows an example of two spectra obtained at 20° and 120° , but at twice the conversion gain called for in step 11.
22. At the completion of the measurements, replace the shield over the source collimator opening to shut off the flux of gamma rays.

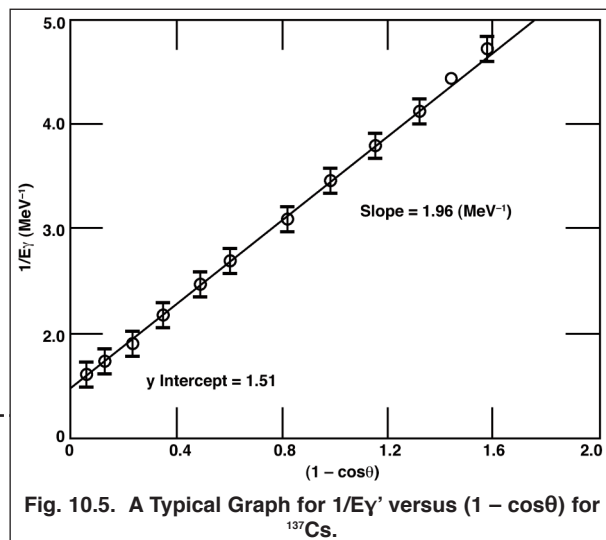
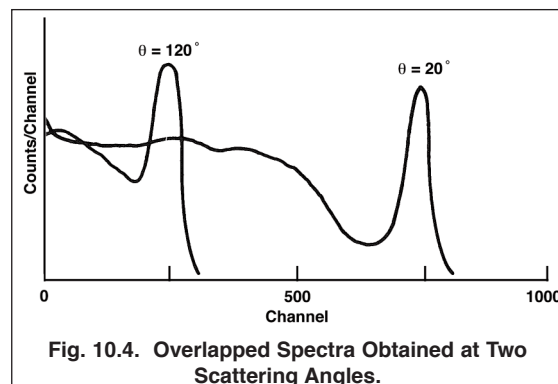

EXERCISES

- a. Plot the $E_{\gamma'}$ values calculated from Equation (4) versus θ on linear graph paper. Add your measured values of $E_{\gamma'}$ together with ± 1 -sigma error bars from equation (6). Explain the reasons for any discrepancies between the theoretical and measured values for $E_{\gamma'}$.
- b. Plot your measured values of $1/E_{\gamma'}$ versus $(1 - \cos\theta)$ on a linear graph. Equation (6) gives the predicted standard deviation in the measured $E_{\gamma'}$. Convert that standard deviation into the corresponding error for $1/E_{\gamma'}$, and add the appropriate error bars to your points on the graph. Draw a best fit straight line through your measured points. Read the slope of the straight line and its intercept from the graph. Explain any discrepancy between those graphical values and the prediction from equation (5b). Your graph should look similar to Figure 10.5.

Angle (θ)	$1/E_{\gamma'}$ (MeV^{-1})	$1 - \cos\theta$
0	1.51	0
10	1.54	0.015
20	1.63	0.060
30	1.77	0.133
40	1.97	0.234
50	2.20	0.357
60	2.49	0.500
70	2.79	0.658
80	3.12	0.826
90	3.46	1.00
100	3.80	1.17
110	4.13	1.34
120	4.44	1.50
130	4.72	1.64

EXPERIMENT 10.2. Simple Compton Scattering: Cross-Section Determination

Purpose

The data collected in Experiment 10.1 will be used to calculate the measured scattering cross-section and compare it to the theoretical cross-section.

Relevant Information

Theoretical Differential Cross-Section

The differential cross-section for Compton scattering, first proposed by Klein and Nishina, is discussed in ref. 1. The theoretical expression for unpolarized gamma rays has the following form:

$$\frac{d\sigma}{d\Omega} = \frac{r_0^2}{2} \left\{ \frac{1 + \cos^2\theta}{[1 + \alpha(1 - \cos\theta)]^2} \right\} \left\{ 1 + \frac{\alpha^2(1 - \cos\theta)^2}{[1 + \cos^2\theta][1 + \alpha(1 - \cos\theta)]} \right\} \quad (7a)$$

Equation (7a) is the differential cross-section for scattering from a single electron, and is expressed in units of $\text{cm}^2/\text{steradian}$. It represents the effective differential area, $d\sigma$, of the electron as a target for scattering the gamma-ray photon at the angle θ into an infinitesimal solid angle, $d\Omega$. The new parameters in equation (7a) are the classical electron radius

$$r_0 = 2.82 \times 10^{-11} \text{ cm} \quad (7b)$$

And the normalized (dimensionless) energy

$$\alpha = \frac{E_\gamma}{m_0 c^2} = \frac{0.662 \text{ MeV}}{0.511 \text{ MeV}} = 1.296 \text{ for } ^{137}\text{Cs} \quad (7c)$$

Experimentally Measured Differential Cross-Section

The data already collected in Experiment 10.1 can be used to calculate the measured differential scattering cross-section by employing equation (8).

$$\left[\frac{d\sigma}{d\Omega} \right]_{\text{measured}} = \frac{\Sigma_{\gamma'}}{n_e I \Delta\Omega t_L \epsilon} \quad (8a)$$

Where n_e is the number of electrons in the portion of the scatterer illuminated by the incident gamma rays. For a scatterer composed of multiple elements, n_e can be calculated from the basic parameters for the material, i.e.,

$$n_e = \rho V N_A \sum_i w_i \frac{Z_i}{M_i} \quad (8b)$$

Where:

ρ is the density of the scatterer in g/cm^3 ,

V is the volume (in cm^3) of the scatterer that is illuminated by the incident gamma rays,

N_A is Avogadro's Number (6.022×10^{23}),

Z_i is the atomic number of the i^{th} element in the scatterer,

M_i is the gram atomic weight of the i^{th} element in the scatterer, and

w_i is the concentration of the i^{th} element in the scatterer, expressed as a weight fraction.

By definition, the weight fractions for all elements in the scatterer sum to unity.

$$\sum_i w_i = 1 \quad (8c)$$

Experiment 10 Compton Scattering

The variable, I , is the number of incident gamma rays per cm^2 per second at the scattering sample. It can be calculated from

$$I = \frac{A_0 f}{4\pi R_1^2} \quad (8d)$$

Where A_0 is the activity of the source (5 mCi), f is the fraction of the decays that result in the emission of 662 keV gamma-rays (0.851) and R_1 is the distance from the source to the center of the scatterer.

The solid angle subtended by the NaI(Tl) detector at the scatterer is computed from

$$\Delta\Omega = \frac{\pi \left(\frac{D}{2}\right)^2}{R_2^2} \quad (8e)$$

Where $D = 5.08$ cm is the diameter of the NaI(Tl) scintillation crystal, and R_2 is the distance from the center of the scatterer to the front surface of the NaI(Tl) detector.

Σ_Y is the total number of counts in the photopeak for the scattered gamma ray acquired during the live time, t_L . The intrinsic photopeak efficiency, ϵ , can be obtained from Fig. 10.6.

Note that Figure 10.6 differs from the virtually identical graph in Experiment 3. There were no measured values at 0.124 MeV in the original graph for the 2" x 2" and 3" x 3" detector sizes. For the purposes of Experiment 10, these points have been interpolated between $\epsilon = 1.00$ and the measured value on the 1.5" x 1.5" curve. Although adequate for this experiment, the interpolated values are not reliable for more general use.

For convenience, the elemental composition for the aluminum rod alloy is listed in Table 10.4. According to the ASTM standard, the composition can vary over the range in columns 2 and 3. For the purposes of this experiment, the mean of the maximum and minimum concentrations has been tabulated in column 4. The calculation in equation (8b) can be simplified further by ignoring elements with concentrations $<0.6\%$. That approximation would elevate the Al concentration to 98.4%. Note that the weight fraction used in equation (8b) is simply the percent concentration divided by 100%.

Procedure

The data for this experiment has already been measured and recorded in Experiment 10.1.

EXERCISES

- Compute $d\sigma/d\Omega$ from Eq. (7) for the values of θ used in Table 10.1. (A spreadsheet is quite valuable for this calculation, although not absolutely necessary).

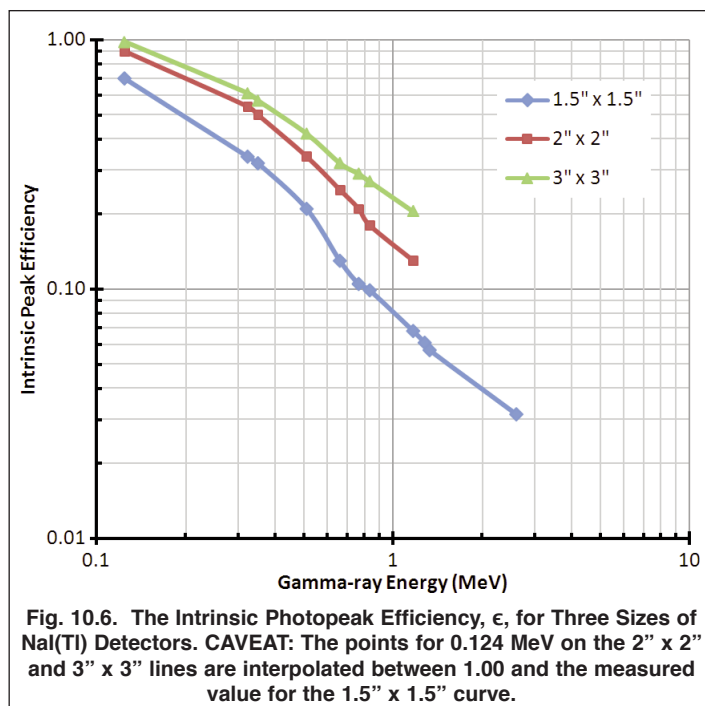

Fig. 10.6. The Intrinsic Photopeak Efficiency, ϵ , for Three Sizes of NaI(Tl) Detectors. CAVEAT: The points for 0.124 MeV on the 2" x 2" and 3" x 3" lines are interpolated between 1.00 and the measured value for the 1.5" x 1.5" curve.

Table 10.4. The Composition of the Aluminum Scatterer.			
ASTM Aluminum Alloy 606-T651			
Density = 2.7 g/cm^3			
Element	Min. Weight %	Max. Weight %	Nominal (Mean) Weight %
Al	95.8	98.6	97.23
Mg	0.8	1.2	1.00
Si	0.4	0.8	0.60
Fe		0.7	0.35
Cu	0.15	0.4	0.25
Cr	0.04	0.35	0.20
Zn		0.25	0.13
Mn		0.15	0.08
Ti		0.15	0.08
Other		0.15	0.08

- b. Plot the theoretical $d\sigma/d\Omega$ versus θ on a linear graph.
 - c. Use the data measured in Experiment 10.1 with equations (8) to calculate $[d\sigma/d\Omega]_{\text{measured}}$, and plot your measured values on the graph from step b.
 - d. Estimate the standard deviation in your measured values based on counting statistics. Add the error bars to the points on the graph in step c to represent the ± 1 -sigma predicted errors.
 - e. Discuss possible reasons for any discrepancies between the theoretical and measured differential cross-sections.
-

EXPERIMENT 10.3. Compton Scattered Energy: Coincidence Method

Purpose

In this experiment the aluminum rod is replaced with a plastic scintillator, which functions as the scatterer. The measurement of scattered energy versus angle is repeated, with the improvement offered by requiring a coincidence between the plastic scintillator and the NaI(Tl) detector.

Procedure

Installation and Connections

1. Use the electronics that were set up and calibrated in Experiment 10.1. Make the additions and modifications outlined below, as illustrated in Fig. 10.7.
2. Remove the aluminum rod that was used as the scatterer in the previous experiment. Mount the cylindrical plastic scintillator in place of the aluminum rod. The photomultiplier and PMT base will extend above the scintillator rod.
3. Turn off the 556 HV Power Supplies and the NIM Bin power. Install the additional modules in the bin.
4. For the 556 HV Power Supply dedicated to the plastic scintillator, confirm that the POLARITY switch on the rear panel is in the POSitive position. Check that the CONTROL switch is set to INTernal. Using an RG-59A/U coaxial cable with SHV plugs, connect one of the high voltage OUTPUTS on the rear of the 556 to the POSitive HV input on the 266 PMT Base that is committed to the plastic scintillator. Set the voltage controls on the front panel of the 556 to the value recommended by the manufacturer of the plastic scintillator detector.

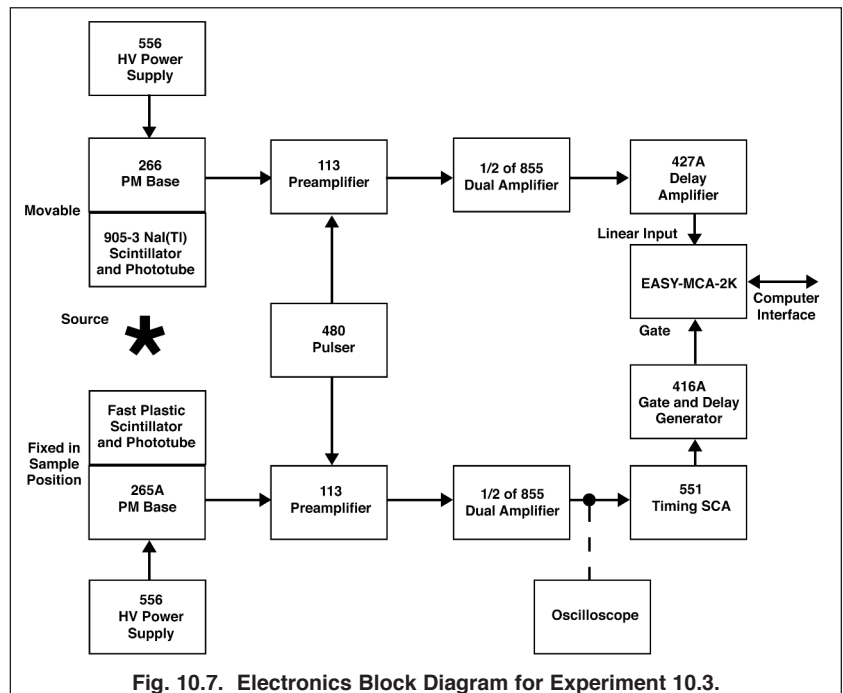

Fig. 10.7. Electronics Block Diagram for Experiment 10.3.

5. Using a short 93- Ω RG-62A/U cable, connect the ANODE output of the 266 PMT Base to the INPUT of the second 113 Preamplifier. Set the Preamplifier INPUT CAPacitance to 100 pF.
6. On the 855 Dual Amplifier, confirm that the printed-circuit-board-mounted jumpers are set for a NEGative input polarity, and the SHAPING TIME switches are set to 0.5 μs .
7. Connect the POWER cable from the second 113 Preamplifier to the available PREAMP POWER plug on the rear panel of the 855. Using a 12-ft. (3.7-m) RG-62A/U 93- Ω coaxial cable, connect the 113 OUTPUT to the unused INput on the 855 Dual Amplifier.
8. With a short 93- Ω coaxial cable, connect the unused UNIpolar output of the 855 to the DC INPUT of the 551 Timing SCA.

Experiment 10

Compton Scattering

- On the 551 Timing SCA set the output delay range switch to 0.1 – 1.1 μsec . With the INT/NOR/WIN switch, select the NORMAL mode. Set the DELAY dial to its minimum value and lock the dial. Turn the UPPER LEVEL control to 1000/1000 (i.e. 10.00 V). Choose 10/1000 (i.e., 100 mV) on the LOWER LEVEL control. Lock both dials to prevent inadvertent changes. Check that the LL REF and STROBE switches on the rear panel are both set to the INTERNAL mode.
- Using a short 93- Ω cable, connect the POSITIVE OUTPUT of the 551 Timing SCA to the POSITIVE INPUT on the 416A Gate and Delay Generator. Set the DELAY range switch to 11 μsec , and turn the DELAY dial to its minimum (counter clockwise) value. Connect the POSITIVE DELAYED OUTPUT to the GATE input on the EASY-MCA-2K with a 93- Ω RG-62A/U coaxial cable.
- For the half of the 855 Dual Amplifier already processing signals from the NaI(Tl) detector, connect the UNIPOLAR output to the INPUT on the 427A Delay Amplifier via a short, 93- Ω coaxial cable. Set all the DELAY slide switches to the OUT position. With a 93- Ω cable, connect the OUTPUT of the 427A to the linear analog INPUT of the EASY-MCA-2K.

Adjustments and Calibration

- Insert the 480 Pulser in the Bin and turn on the NIM Bin power. Check that the correct bias voltages have been selected, and turn on the power for both 556 HV Power Supplies.
- Place the 1 μCi ^{137}Cs source next to the plastic scintillator and observe the UNIPOLAR output of its half of the 855 Amplifier on the oscilloscope. Adjust the gain of the amplifier so that the Compton edge of the ^{137}Cs signal is at approximately +6 V. The Compton edge is represented by the largest pulse heights from the source. Lock the FINE GAIN dial.
- Using the procedure developed in Experiment 3, adjust the Pole-Zero (P/Z) cancellation on the half of the 855 Amplifier dedicated to the plastic scintillator to make the output pulses return to baseline as quickly as possible without undershooting.
- Ensure that the MAESTRO-32 menu has the gate requirement turned off for the EASY-MCA-2K. Perform an energy calibration of the MCA for the NaI(Tl) detector using the low activity sources, as was implemented in step 16 of Experiment 10.1. (The insertion of the 427A Delay Amplifier will slightly alter the energy versus pulse height calibration.)
- Note which half of the 855 amplifier has the larger gain setting. Using a long 93- Ω coaxial cable, connect the ATTENUATED OUTPUT of the 480 Pulser to the 113 Preamplifier TEST PULSE that is served by the higher-gain half of the 855. Connect the DIRECT OUTPUT to the TEST PULSE input on the other 113 Preamplifier. Select a NEGATIVE polarity on the 480, and turn the Pulser on.
- On the oscilloscope, observe the pulses from the half of the 855 Amplifier that has the lower gain. Adjust the PULSE HEIGHT dial on the 480 Pulser to produce a pulse height of approximately +5 V at the amplifier UNIPOLAR output. Lock the PULSE HEIGHT dial.
- Observe the UNIPOLAR pulses from the other half of the 855 Amplifier. Adjust the ATTENUATOR switches on the 480 Pulser to achieve a pulse height anywhere in the range of +2 to +8 Volts.
- Reconnect the amplifier outputs to their respective destinations, as illustrated in Fig. 10.7. Observe the 427A Delay Amplifier OUTPUT on channel 1 of the oscilloscope, and trigger the oscilloscope on the leading edge of that pulse on channel 1. Connect the 416A POSITIVE DELAYED OUTPUT to channel 2 on the oscilloscope, and simultaneously observe both channel 1 and channel 2 while triggering on channel 1.
- Adjust the 416A AMPLITUDE control to achieve a POSITIVE DELAYED OUTPUT pulse height between +5 and +10 Volts.
- Check that the DELAY dials on the 551 and 416A are set to their minimum values.
- On the 427A Delay Amplifier add the minimum delay that moves the maximum amplitude of the amplifier pulse to arrive at least 0.5 μs after the leading edge of the logic pulse from the 416A. Adjust the DELAY dial on the 416A to make the peak amplitude of the amplifier pulse arrive exactly 0.5 μs after the leading edge of the 416A logic pulse. Lock the DELAY dial.

Experiment 10 Compton Scattering

23. Adjust the WIDTH control on the 416A so that the trailing edge of the logic pulse from the 416A falls 1 μ s after the peak amplitude of the amplifier pulse. This should ensure proper alignment of the gating signal. Turn off the Pulser.
24. Trigger the oscilloscope on the 416A logic pulse on channel 2. Verify, that the 551 Timing SCA is not producing a high counting rate caused by triggering on the electronic noise from the plastic scintillator signal processing electronics. This can be quickly checked by lowering the 551 LOWER LEVEL until the counting rate escalates abruptly on the noise. Raise the 551 SCA LOWER LEVEL safely above that noise level. If noise does not appear to be a problem, the LOWER LEVEL can be left at 10/1000 (100 mV).
25. Reconnect the amplifier outputs to their respective destinations, as illustrated in Fig. 10.7. Via the MAESTRO-32 menus select the Coincidence Gate requirement for data acquisition on the EASY-MCA-2K.

Acquire the Gamma-Ray Spectra Versus Scattering Angle

26. Remove all energy-calibration sources. Next, remove the cover shield from the collimator on the 5 mCi ^{137}Cs source enclosure.
27. Repeat the data acquisitions outlined in steps 18 through 22 of Experiment 10.1.

EXERCISES

- a. Repeat the Exercises from Experiments 10.1 and 10.2 with the new coincidence data. The plastic scintillator parameters needed for calculating the measured differential cross-section are listed in Table 10.5. In this case equation (8b) is not employed. Instead, the total number of electrons, n_e , is calculated by multiplying the number of electrons per cm^3 from Table 10.5 by the illuminated volume, V .
- b. How do the results from Experiment 10.3 differ from the graphical plots in Experiments 10.1 and 10.2?
- c. Identify any benefits and disadvantages associated with the coincidence method.

ASI-100 Plastic Scintillator (Alpha Spectra, Inc.)	
Density	1.02 g/cm ³
Number of H atoms per cm ³	5.17E+22
Number of C atoms per cm ³	4.69E+22
Number of electrons per cm ³	3.33E+23

EXPERIMENT 10.4. Measuring the Electron Recoil Energy from Compton Scattering

Purpose

Using the coincidence technique set up in Experiment 10.3, the electron recoil energy in the plastic scintillator will be measured as a function of the Compton scattering angle, θ .

Relevant Information

From equation (4), the energy for the recoiling electron in the plastic scintillator can be calculated as

$$E_e = E_Y - E_{Y'} \quad (9)$$

Procedure

1. Calculate the theoretical recoiling electron energy from Equation (9) and enter that data in Table 10.6 for the specified angles.
2. Continue with the electronics as set up and calibrated at the end of Experiment 10.3.

θ (degrees)	Calculated E_e (MeV)	Measured E_e (MeV)	Preset Live Time, t_L (seconds)	Photopeak Sum, Σ_e	Photopeak FWHM (MeV)
0					
20					
40					
60					
80					
100					
120					
140					
160					
180					

Experiment 10 Compton Scattering

- As illustrated in Fig. 10.8, make the following changes.
- The destinations of the two amplifier outputs will be interchanged so that the pulse height from the plastic scintillator can be analyzed by the MCA, while the pulses from the NaI(Tl) detector gate the MCA. Connect the 855 UNipolar output from the NaI(Tl) detector to the DC INPUT of the 551 Timing SCA. Connect the 855 UNipolar output that serves the plastic scintillator to the 427A Delay Amplifier INPUT.
- Remove or shut off all radioactive sources, and turn on the 480 Pulser.
- Observe the 427A Delay Amplifier OUTPUT on channel 1 of the oscilloscope, and trigger the oscilloscope on the leading edge of that pulse on channel 1. Connect the 416A POSitive DELAYED OUTPUT to channel 2 on the oscilloscope, and simultaneously observe both channel 1 and channel 2 while triggering on channel 1.

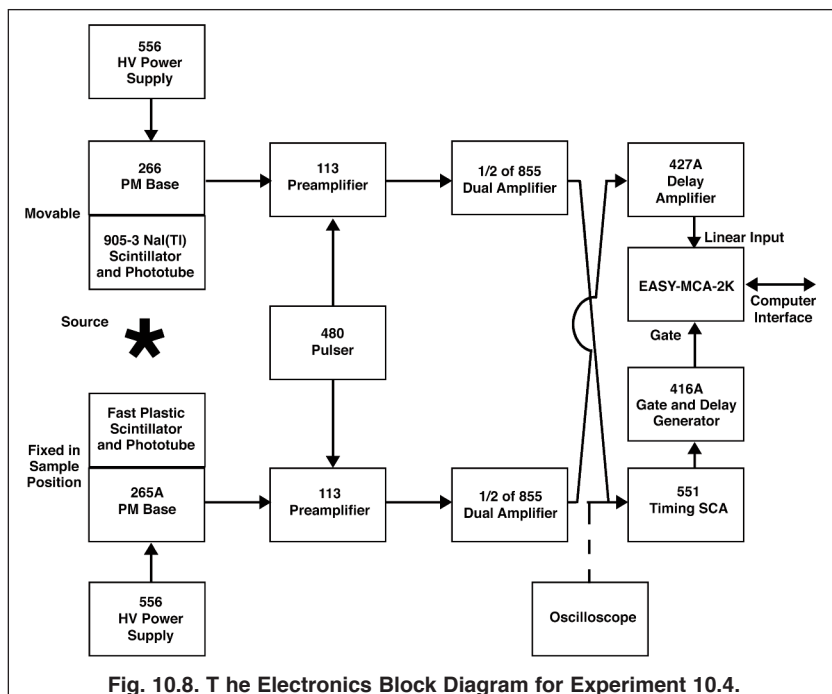

Fig. 10.8. The Electronics Block Diagram for Experiment 10.4.

- If necessary, adjust the delay on the 427A Delay Amplifier and the DELAY dial on the 416A Gate and Delay Generator to make the peak amplitude of the amplifier pulse arrive exactly $0.5 \mu\text{s}$ after the leading edge of the 416A logic pulse. Any required readjustment should be minor. Lock the DELAY dial, and turn off the 480 Pulser.
- Trigger the oscilloscope on the 416A logic pulses on channel 2. Verify, that the 551 Timing SCA is not producing a high counting rate caused by triggering on the electronic noise from the NaI(Tl) signal processing electronics. This can be checked quickly by lowering the 551 LOWER LEVEL until the counting rate escalates abruptly on the noise. Raise the 551 SCA LOWER LEVEL safely above that noise level. If noise does not appear to be a problem, the LOWER LEVEL can be left at 10/1000 (100 mV).
- Reconnect the amplifier outputs to their respective destinations, as illustrated in Fig. 10.8. Via the MAESTRO-32 menus turn the Coincidence Gate requirement OFF for data acquisition on the EASY-MCA-2K.
- Place a $1 \mu\text{Ci } ^{137}\text{Cs}$ source next to the plastic scintillator, and collect a spectrum long enough to achieve adequate statistical precision in the Compton distribution. The spectrum should look like Fig. 3.4 in Experiment 3, except there will be no photopeak, and the backscatter peak will be missing. Measure the channel position of the Compton edge. This is best estimated by finding the point on the Compton edge that has a counting rate that is 50% of the counting rate of the Compton plateau at slightly lower energies.
- Remove the ^{137}Cs source. Set the 480 PULSE HEIGHT dial to 478 (the ^{137}Cs Compton-edge energy) and lock the dial. Connect the ATTENUATED OUTPUT to the TEST PULSE input of the 113 Preamplifier serving the plastic scintillator. Disconnect the DIRECT OUTPUT from the other preamplifier, and place the 100- Ω terminator on the DIRECT OUTPUT. Turn on the Pulser. Adjust the ATTENUATOR switches and the CALIBRATION screwdriver control so that the Pulser peak grows at the same channel number as the 478 keV Compton edge from the ^{137}Cs source. Generate an energy calibration curve by acquiring pulser peaks at 4 or 5 additional dial settings between 478 and 50 keV. Use these peaks to calibrate the EASY-MCA-2K cursor to read directly in energy. Turn off the Pulser.
- Remove the shield from the source collimator opening to allow the ^{137}Cs gamma-rays from the 5 mCi source to illuminate the plastic scintillator.
- Via MAESTRO-32 turn on the Coincidence Gate requirement for the EASY-MCA-2K.

Experiment 10 Compton Scattering

14. Position the NaI(Tl) detector at $\theta = 60^\circ$. This is the position at which the lowest counting rate will be recorded. Set the preset live time on the EASY-MCA-2K at 100 seconds, and acquire a spectrum for that live time. A recoil electron peak should be recorded as illustrated in Fig. 10.9.

15. Set a Region of Interest (ROI) across the entire electron recoil peak. Sum the counts in the peak using the ROI integration feature of the MAESTRO-32 software.

16. From the result in step 15, determine the preset live time necessary to accumulate at least 1,000 net counts in the electron recoil peak. Use this preset live time for acquiring the spectra at each of the angles in Table 10.6.

17. For each angle in Table 10.6 (except 0° and 180°), measure the centroid energy of the electron recoil peak, the sum of the counts in the peak, Σ_e , and the FWHM of the peak. Record those numbers in Table 10.6.

18. Once you are comfortable that you have successfully completed the data acquisition, install the shield over the collimator opening on the 5 mCi ^{137}Cs source, and lock the shield in place to minimize unintended exposure to the gamma rays.

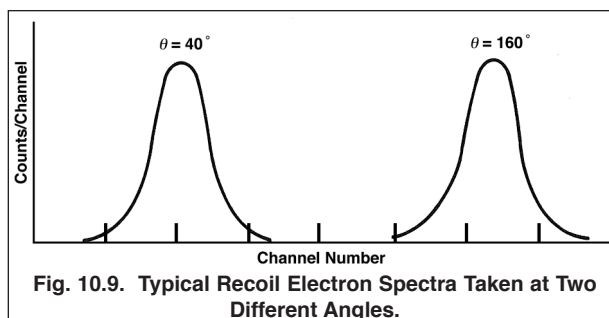

EXERCISES

- Plot the theoretical values of E_e vs. θ from Table 10.6.
- Add your measured values of E_e to the graph, together with the ± 1 -sigma uncertainty from counting statistics calculated from Equation (6). (Substitute Σ_e for Σ_γ in Equation (6).)
- Critique the quality of agreement between measured and theoretical values, and explain any plausible causes of discrepancies.

EXTRA-CREDIT QUESTIONS

- Why is the photopeak that is present in the ^{137}Cs spectrum with the NaI(Tl) detector absent in the spectrum acquired with the plastic scintillator?
- Equations (4) and (9) indicate that the Compton distribution for the recoil energy spectrum should drop abruptly to zero above the maximum energy that can be transferred to the electron from the gamma ray. Why does the Compton edge observed in step 10 drop slowly over a substantial range of energy?
- What determines the FWHM of the recoil electron peaks recorded in Table 10.6?
- Most scintillators that deliver good energy resolution have a diameter that is equal to the thickness. The plastic scintillator used in this experiment is a long, thin rod with the scintillation light collected by the photomultiplier tube at one end of the rod. How does this unusual geometry affect the measured signal?

References

- A.C. Melissinos, Experiments in Modern Physics, Academic Press, New York (1966).
- G. F. Knoll, Radiation Detection and Measurement, John Wiley and Sons, Inc., New York (1979).
- P. Quittner, Gamma Ray Spectroscopy, Halsted Press, New York (1972).
- W. Mann and S. Garfinkel, Radioactivity and Its Measurement, Van Nostrand-Reinhold, New York (1966).
- K. Siegbahn, Ed., Alpha-, Beta-, and Gamma-Ray Spectroscopy, 1, North Holland Publishing Co., Amsterdam (1965).
- C. M. Lederer and V. S. Shirley, Eds., Table of Isotopes, 7th Edition, John Wiley and Sons, Inc., New York (1978).

Experiment 10

Compton Scattering

7. R. L. Heath, "Scintillation Spectrometry", Gamma-Ray Spectrum Catalog, 2nd Edition 1 and 2, IDO 16880, August, (1964). Available from Clearinghouse for Federal Scientific and Technical Information, Springfield, Virginia. Electronic copy available at <http://www.inl.gov/gammaray/catalogs/catalogs.shtml>.
8. G. Marion and P. C. Young, Tables of Nuclear Reaction Graphs, John Wiley and Sons, Inc., New York (1968).
9. D. A. Gedcke, How Histogramming and Counting Statistics Affect Peak Position Precision, ORTEC Application Note AN58, (2005), <http://www.ortec-online.com/Library/index.aspx>.

APPENDIX 10-A: Installing the 5 mCi ^{137}Cs Source in the Shielded Collimator and Checking Alignment

CAUTION

The ^{137}Cs source employed in this experiment has a very high activity (5 mCi). To reduce radiation exposure, handling of the small 6.4 mm diameter source capsule should be minimized, and tongs should be employed to increase the distance from the source capsule to the hands. Once the source is properly installed in the shielded collimator and the cover is secured over the collimator opening, the radiation exposure is reduced to less than that caused by a $1\ \mu\text{Ci}$ source at a minimum distance of 7.6 cm. This shielding can be used for storing the source when not being used in the measurement.

During the Compton scattering experiment, the cover over the collimator opening must be removed. While the cover is open, minimize the time any body parts are inserted into the direct beam of gamma rays streaming through the collimator, and maximize your distance from the source in that direct beam.

For safety, the shielded cover should be applied over the collimator opening whenever the output from the source is not needed. If the enclosed source is left unattended, that collimator cover should be secured with a lock to dissuade tampering.

Installing the Source in the Shielded Enclosure

The shielded collimator enclosure and the 5 mCi ^{137}Cs radioactive source are shipped separately from their manufacturers. Installation of the source into the shielded collimator needs to be implemented by the Laboratory Manager prior to use in any experiments. Observe the above caution about handling this high-activity source. Use the following procedure for installing the source.

1. Remove the cover shield that is secured over the collimator window.
2. Remove any screws that are retaining the front of the collimator section to the main body of the enclosure.
3. Withdraw the collimator and the attached tube from the well in the enclosure.
4. At the end of the tube that is remote from the square collimator window, there is a hole drilled in the circular end-plate along the center line of the tube. The diameter of this hole is slightly larger than 0.25 inches (6.35 mm), and accepts the similar outer diameter of the source capsule.
5. Loosen the clamp at the entrance to this hole, and insert the source capsule with its active end towards the collimator window. Make sure the source capsule is inserted until it is stopped by the lip at the end of the hole. The lip ensures the proper insertion depth.
6. Tighten the clamp so that the source capsule cannot move from its proper position.
7. Insert the source, tube and collimator assembly into the well in the shielded enclosure.
8. Reinstall the retaining screw(s) to hold the collimator/source assembly in the shielded enclosure.
9. Place the shielded cover over the collimator opening, and secure it with a lock and key.

10. Using a radiation dosimeter capable of reading exposure rates as low as 0.1 mR/hr. with gamma-ray energies in the range of 100 to 662 keV, survey the entire outside of the enclosure to determine the exposure rate at the surface of the enclosure. Verify that there are no intolerable exposure rates from gaps in the shielding.
11. When not employed in the experiment, store the source and enclosure in a secure location.

Checking Alignment in the Compton Scattering Experiment

The mechanical keying features on the Angular Correlation Table and the 5 mCi ^{137}Cs source enclosure/collimator should provide proper alignment for the Compton Scattering Experiment. The centerline of the source collimator and the centerline of the NaI(Tl) detector should lie in the same scattering plane. Where that plane intersects the vertical centerline of the aluminum scattering rod or the plastic scintillator rod defines the desired center of the collimated gamma-ray beam at the scatterer. The collimated gamma-ray beam should extend ± 1 inch (± 2.54 cm) in the vertical direction around that centerline. The beam should also extend ± 1 inch (± 2.54 cm) in the horizontal plane with respect to the vertical centerline of the scattering rod.

This alignment can be checked using the plastic scintillator. To measure the horizontal limits of the gamma-ray beam, move the plastic scintillator horizontally across the beam while monitoring the counting rate. To measure the vertical extent of the gamma-ray beam, use the plastic scintillator with its long axis in the horizontal plane, and scan in the vertical direction, while monitoring the counting rate. The distance resolution with this method will be approximately determined by the diameter of the plastic scintillator.

Experiment 10
Compton Scattering

Specifications subject to change
010713

ORTEC[®]

www.ortec-online.com

Tel. (865) 482-4411 • Fax (865) 483-0396 • ortec.info@ametek.com
801 South Illinois Ave., Oak Ridge, TN 37831-0895 U.S.A.
For International Office Locations, Visit Our Website

AMETEK[®]
ADVANCED MEASUREMENT TECHNOLOGY